

SU

SINCLAIR USER

THE SPECTRUM MAG!

ROBIN HOOD
THE LEGEND LIVES!

Full Review Inside

Merlin, The Axe of Kolt 2
Explorer, Pokemania



NO TAPE?? ASK YOUR
NEWSAGENT FOR IT

SUPER FIGHTERS > DW!!
BIFF!!! CODIES WRESTLING HITS TOWN!!

ON TAPE



MERLIN - Fully Playable Game
AXE OF KOLT Part 2 - Adventure
EXPLORER - Powerful +3 Utility
POKEMANIA - Happy New Year!!



GOT A HAND-HELD?..THEN GO! AND GET THIS!

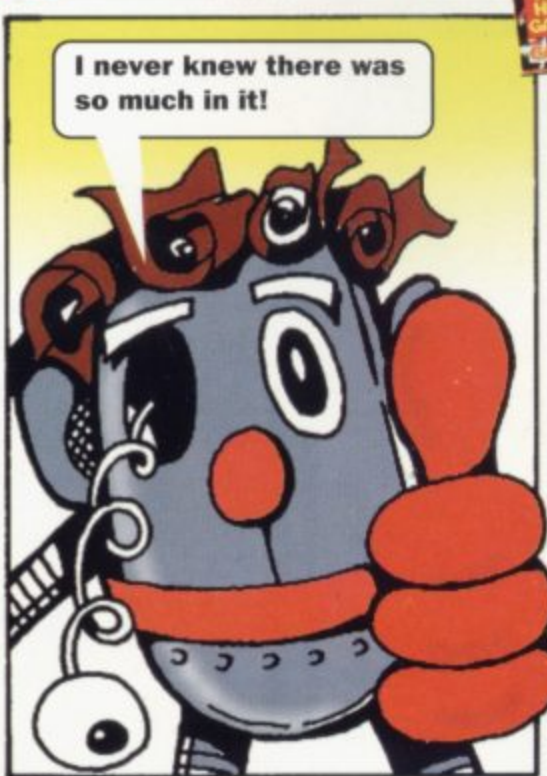
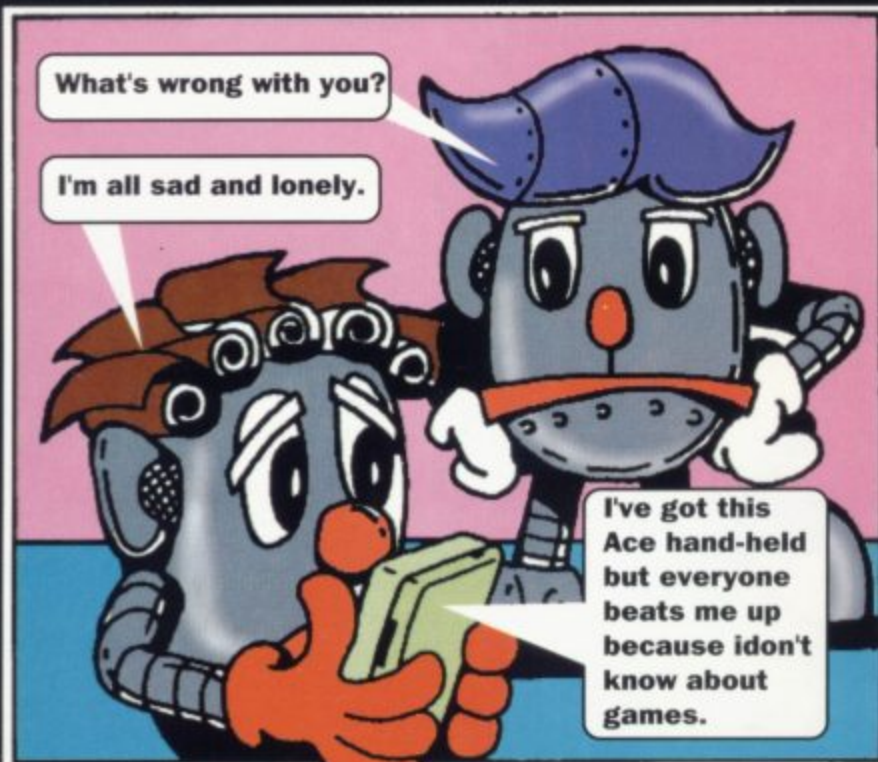

HAND-HELD

GO!

VIDEO GAMES

CAN YOU AFFORD TO MISS IT!

CONTENTS

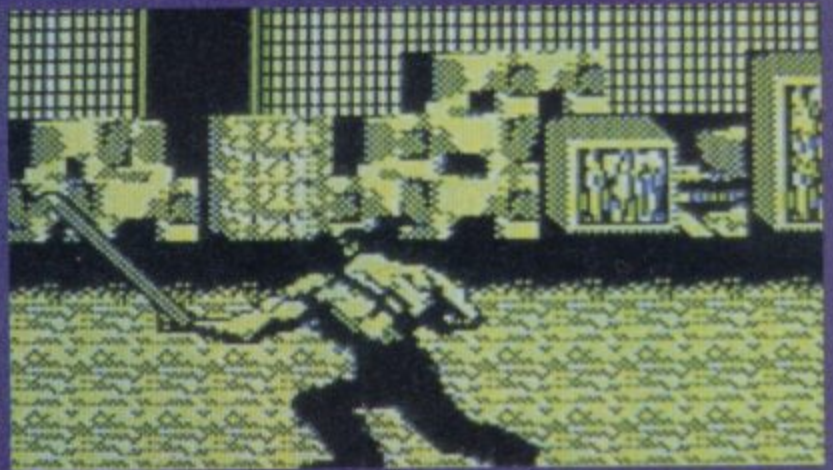

SOFTWARE

Pipemania	Wildcat plumbing japery. SU BEST BUDGET	31
Robin Hood	A really nice little game. SU SILVER	8
Super Fighter	A very muscular compilation. SU SILVER	18
Trivial Pursuit	Brill board game conversion. SU SILVER	31
Wrestling Superstars	Finger blisters Ahoy!	10

THE FUN 4

4

On the Fun 4 this month we've got a special surprise. Not only is there a full game, **Merlin**, originally designed using Animator1, there's also a hackable Merlin sprite for use with the version of Animator1 that we gave away on last months tape or any other version of this excellent program. (Turn to the Animator1 tutorial on page 28 for further details.) The second part of **The Axe Of Kolt** also swings its way onto your Speccy screens. There is a +3 Disk saver and hacker program by Turbo and of course, how could we survive without it, **Pokemania**.

HACKING SQUAD

12

Once again, the man they call Garth has explored the far reaches of human knowledge and returned with quite a nice little bundle of hints, tips, POKEs 'n wossanames. Of special interest to his mum this week will be a complete map for Gunpowder, Treason and Plot, some rather spiffy hints for Super Fruit Machine and a whole host of other things weird and wonderful.

ADVENTURE WRITING

28

Larry Horsfield's adventure writing tutorial has reached an end! Tune in to page 28 as Mr. Adventure saddles up his horse and gives the next generation of writers some sound advice.

ANIMATOR1 TUTORIAL PART 2

20

The second part of the tutorial 'All About Animator1' which was featured on last months Fun 4. Also don't forget the special offer on page 30 giving you a £5 discount when buying the full version of this superb animation package.

REGULARS

CHARTS	30
CHECKOUT	32
SORCERESS	24
SPECMAN	17
TELL IT TO AL	22
SUCK UP	23
UP FRONT	6

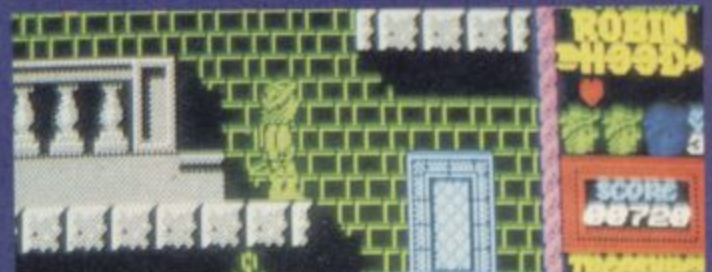

BACK ISSUES

IF YOU'VE MISSED OUT ON ICON GRAPHICS OR ANY OTHER MEGA GREAT & PROGRAMS, OR YOUR COLLECTION IS MISSING ONE OR TWO SU'S DON'T WORRY, YOU CAN GET BACK ISSUES BY PHONING THE FOLLOWING NUMBER: (0858) 410 510 AND ASKING FOR SINCLAIR USER BACK ISSUES. FOR SUBSCRIPTIONS CALL (0733) 898 100.

TAPE RETURN ADDRESS

If you have a faulty tape DO NOT return it direct to SU Towers 'cos we CAN'T do any thing with it. Return your tape to **Spool Duplication, Unit 30, 1st Avenue, Deeside Industrial Estate, Clywd, CH5 2NV** Uncle Harold's our man there and he'll deal with it.

EDITOR: Alan 'Doc Marten' Dykes - DESIGN: Yvette 'Riding Boots' Nichols - SU CREW: Garth 'Clogs' Sumpter, Steve 'Biker Boot' Keen, Philip 'Chelsea Boot' Lindey, Graham 'Sandal' Mason, Pete 'Slipper' Gerrard, Ed 'Bare Feet' Laurence. - AD MANAGER: Tina Zanelli - Ad Production: Tina Gynn - MR. MARKETING: Mark Swallow - MARKETING LADIES: Sarah Hilliard, Sarah Ewing - PUBLISHER: Mike Frey - MANAGING DIRECTOR: Terry Pratt - © 1992 Emap Images Ltd. Part of EMAP PLC. - TEL: (071) 972 6700 - FAX: (071) 972 6701 - SU Priory Court, 30 - 32 Farringdon Lane, London EC1R 3AU - Colour By Colourtech - Printed By Riverside Press Gillingham - Typeset By Altyp inc. - Subs: (0733) 898 100 - Back Issues: (0858) 410 510 - Absolutely no part of this publication may be reproduced, stored in an electronic retrieval system or copied without the express written permission of the publisher. 'Oh I wish it could be Christmas every day... La la la la'. Hope y'all enjoyed the festive season and are looking forward to another year of festive Speccing. I know all of us here at SU are!

THE FUN

4

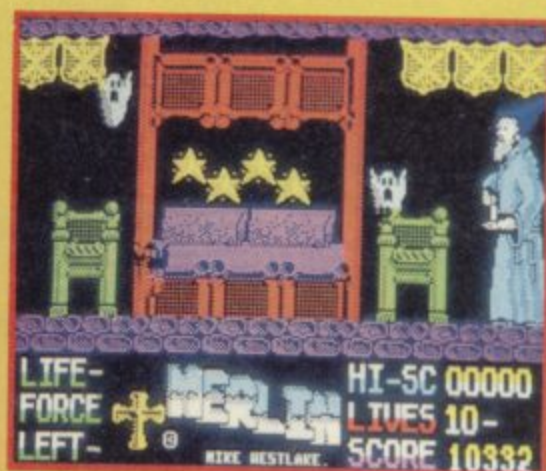
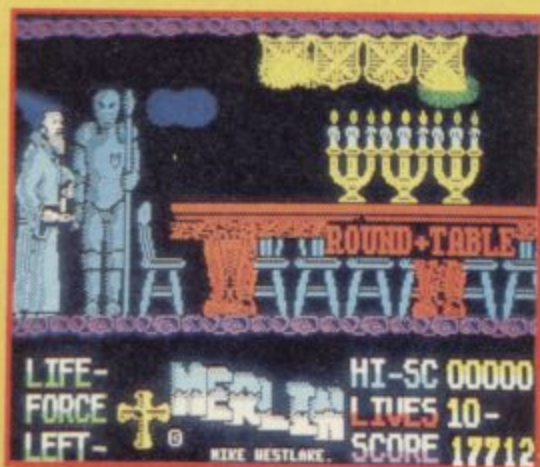

MERLIN

Load In 48K Mode

Thundering incantations, it seems as if all hell has broken loose at Camelot. It may have been a love potion that went wrong or a spell for warts that backfired but the castle is alive with magic. Merlin the Magician, King Arthur's personal spell caster must rush around the castle and try to put things right.

The lumps of raw magic are lying around the castle disguised as glittering stars and to score points these stars must all be collected.

The magic has brought all manner of things to life from books to broomsticks, as well as calling up a nasty collection of spooks and ghouls.

Your journey takes you through all the different rooms in the castle, from the dungeons, where bugs as big as dogs threaten life and limb, through the library, where the books fly about

of their own accord because of all the magic in the air. You will also pass through King Arthur's throne room and out onto the ramparts of Camelot.

With well drawn sprites and backgrounds and plenty of action, a magical time is guaranteed for all!

Controls:

Q - Jump
A - Duck
O - left
P - Right
I - Pause

4



ADDED BONUS!!!

After POKEMANIA you will find two more files called MERLIN1 and MERLIN2. MERLIN1 is actually the main sprite for the full game, Merlin, and MERLIN2 is its colours so you can rede-

sign it and load it back into the game using Animator1. For full instructions on how to do this turn to the Animator1 tutorial and read very carefully. If you use it properly you'll be able to load your own new sprite back into the game and play on!

SU CREW

Christmas is over and you can be darn sure that some idiots have given their friends, nieces, nephews or other relations a pet as a present. This is a really crap idea folks. Having a pet takes

time and thought and so many are abandoned after the hols that it's really disgusting. The SU Crew prefer to see naturally wild animals or well looked after family pets.

ALAN

My favourite animal is Dusty, my family's dog. He's so cute and intelligent it's unbelievable. He's 12 years old now and very well looked after. In fact my mum gives him preferential treatment over everybody else (lucky little devil).



YVETTE

I like dumb animals a lot and my favourite has to be Big Al'. He's so cute and cuddly and does everything I ask him to. It's a pity the conversation isn't more stimulating though. Oh well! (Yvette's in big, BIG trouble!! - Al')



EXPLORER +3 UTILITY

Load In 48/128K Mode

This utility is designed for plus 3 owners who wish to hack into their own disks or a look at non +3 format disks. It will allow you to examine just about any kind of disk format ever invented for the computer. In the right hands it's a very powerful tool. It's possible to edit loaded tracks and then resave them back to disk. However this facility is only available to +3 multiface owners. Used incorrectly, however, things can go wrong so please don't attempt to use it on your own disks until you're sure of what you're doing as you will probably make them unusable.

Before you use the options ensure that your own valuable disks are write protected. You have been warned!!

Uses and instructions:

1. Format (speaks for itself, but more later)
2. Read index. This reads the track or sector under observation and provides the following info: How many sectors are on the track and what size they are. A standard sector is

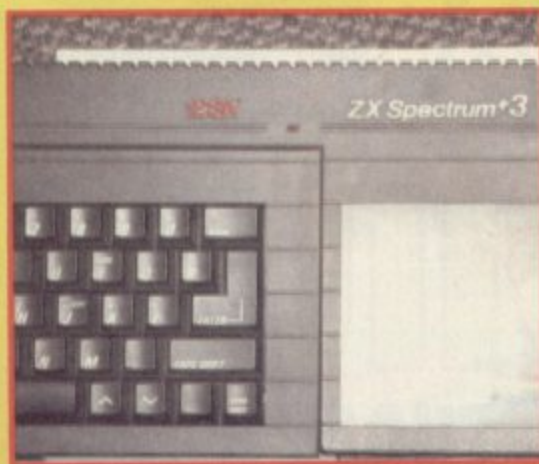

2x256 bytes. If any other value is present, different, probably protected formats have been used.

3. Read data. This loads in the full track or sector and plonks it into the +3 memory for examination by the D key. You can activate your Multiface 3 and alter the data by using the ASCII command.
 4. Write Index to disk. After altering the data you can save it to new disc or back to the one you were messing about with.
 5. Write data. Option 4 just prepares the disk for the data to be written, this option puts the tracks down.
- Y - Move down a track i.e. 4 3 2 1 etc.
T - Move up a track i.e. 1 2 3 4 etc.
E - Explore disk. This examines the full

disk including all format and sector sizes and displays them on the screen.
D - Disassemble in ASCII all the loaded tracks.

C - Compare a loaded track in memory with that of another disk.
M - Toggles display to load either single sectors or full tracks.

At all times break aborts a command and then pressing 'A' will take you back to the Main Menu.

When pressing 1, for the format command, lots of options get displayed on the screen, pressing the O key does a normal format of that disk. The other options on this menu are for parameters that could be used to create your own disk formats. Playing with these is really the best way to see what they do.

REMEMBER it's best to try this program on a blank preformatted disk to see what happens. You can format the disk using 1 and then load it back using 2 and 3 and examining it with D to see what it did.

Once you've played around with this utility if there are any further uses you find for it or if you simply want to find out more then write to SU's Specman, at the usual address, he's the man with the plan! Unfortunately we will not be able to take telephone enquiries 'cos we've got to write the mag not answer the phone.

THE AXE OF KOLT PART 2

Load In 48K Mode

Have you got all you need from the village? Have you defeated the bad guys in the forest? Have you reached the end of Part 1? Do you want to know what to do next? Well simply bleep Part 2 into your Speccy and load your saved position from last month's adventure and you're away once again.

Full playing instructions were in last month's issue but seeing as how we're all very nice here in SU Towers we'll print a full solution to these first two parts next month. And there's more to come!

Remember, before you stop playing you must save your position to tape or all will be lost.

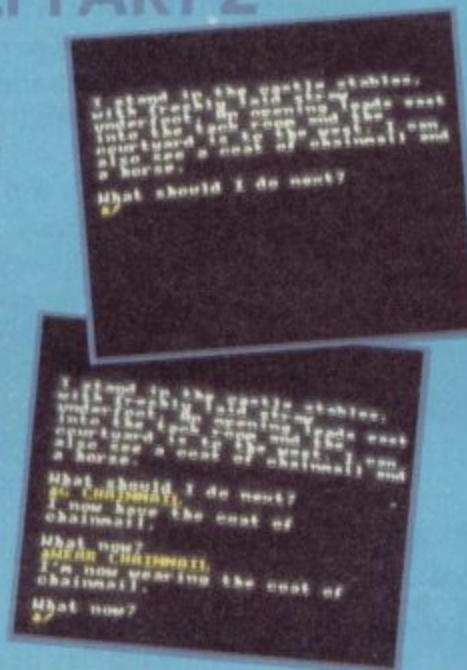

POKEMANIA

Load In 48K Mode

Yes, there's more fabbo POKEs, scrollers, borders and badly spelt messages on this months FUN 4. Just load in Pokemania, select the required POKE from the load in POKEs menu and then load your game. The path to extra lives and invincibility has never been simpler. Way Hey!

PLEASE INSURE NO COPYRIGHT INFRINGEMENT TAKES PLACE. WE DO NOT CONDONE SOFTWARE PIRACY!!!

GARTH

I'm not really into pets, I'm a material man so I've got a rock and an old pair of shoes which I stroke and fondle regularly. I also like to count and cuddle the wads of money that Big AI pays me for writing reviews and doing the Hacking Squad.



PHILIP

My fave animals of all time are whales. They are so big and majestic and if you've ever listened to them singing on TV wildlife programs you'll know how beautiful they sound. I don't know why people seem intent on making them extinct.



STEVE

Steve Keen, boy wonder and Korean cuisine connoisseur likes cats, dogs and pigeons. 'They taste lovely with a bit of sliced ginger, some spices and vegetable stock'. 'And they're really easy to disguise as chicken too.' Everyone loves 'em.



UPfront

WHERE HAVE ALL THOSE LOVELY GAMES GONE?

There is an old saying 'No news is good news' well we here at SU would like to say tish and piffle to old sayings like that. Under the circumstances no news is bad news. I am of course referring to the current situation with two of the biggest games which were supposed to be released for Christmas; Street Fighter 2 from US Gold and Nigel Mansell from Gremlin. We've been promising them for months now but unfortunately the final versions of these games have not yet been tested. They are definitely on the way though and we've been assured that the products have just 'slipped' and aren't being stopped. Andy Watt, US Gold's PR supremo (Oops, sorry Woody!) claims that Street Fighter 2 will definitely be ready around mid January so be patient, we'll give you the real story then.

6

STREET FIGHTER II

HAS TINA GONE SOFT?

Tina Zanelli, SU's well known and much admired advertising manager has been causing a spot of bother for one of her advertisers recently. Most people would pay just to listen to her dulcet tones over the phone but the big boss man over at Sigmasoft has had cause for consternation recently and no it's not because the lovely Tina's voice has broken. You see we've had their address printed incorrectly for the last few issues and Sigmasoft's neighbours aren't pleased. The correct address is in fact 8 Pine Dale, Rainford, Merseyside, WA11 8DP. Sorry Sigmasoft, and anyone else this has effected.

SIGMASOFT



OCEAN WAKES UP TO COMIC RELIEF

As we all know by now Comic Relief takes place every year to help people in need both here in the UK and in Africa. Lenny Henry and his entourage of funsters are hoping to split our sides until the money flows out on RED NOSE DAY 4, 12th March 1993. However this time around Ocean Software have added a new dimension to the proceedings with the announcement of a special Red Nose Day game, and they hope to raise over £500,000 for the cause with it.

The game will be called Sleep Walker and is due for release in January. Unfortunately it's not going to be available on the Spectrum but if a friend of yours (or you, own up!) has either an ST, and Amiga or a PC then buying this game is a darn good way of helping out a good cause. An average of £5.00 per game sold will go to the charity.

Each copy of Sleep Walker comes with a sponsorship form so you can make wads of cash for Comic Relief by getting sponsorship to play the game... What a deal! Then all you have to do is register with the Red Nose Day Sleep Walker challenge which will be active in major retail outlets all over the country and, if you play well enough, you could get to take part in a grand final to be held in central London on the big day itself, 12th March.

Now if only they wouldn't allow people to put those poncy red noses on the front of their cars...

COMIC -RELIEF

FREE! ZOOOL PACK WITH EVERY AMIGA

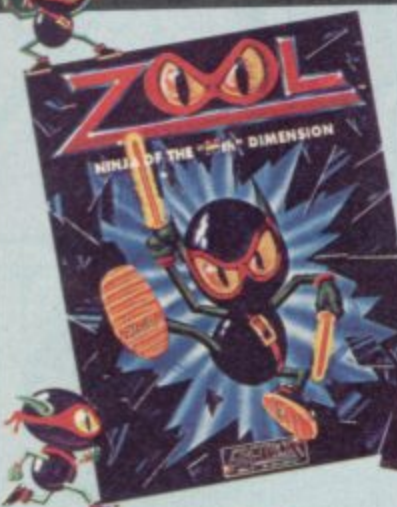

Silica are pleased to offer THE Software Pack of the Year FREE with every Amiga purchased. It includes the sensational new title ZOOOL which has received rave reviews as the most original game ever seen on the Amiga.

ZOOOL - "Knocks the socks off Sonic." - 97% - Amiga Computing - Nov '92
 STRIKER - "Footballer of the Year - and no mistake..." - 94% - CU Amiga - June '92
 PINBALL DREAMS - "It's quite simply superb" - 94% - AUI - Sept '92
 TRANSWRITE - Premier word processor (UK version) with a 90K spell checker.

Plus, with every Amiga from Silica, we will give you Photon Paint 2 paint package and GFA Basic programming language. A total of over £265 worth of free gifts.

ZOOOL PACK:
 ZOOOL - platform title of the year £25.99
 STRIKER - soccer simulation £25.99
 PINBALL DREAMS - pinball simulation £25.99
 TRANSWRITE - word processor £49.95

PLUS!
 GFA BASIC v3.5 - programming language £50.00
 PHOTON PAINT 2 - paint package £89.95
£267.87

500 or 600 FROM SILICA SYSTEMS

PLUS! PHOTON PAINT 2 AND GFA BASIC

WORTH OVER £265



AMIGA 500 Plus CARTOON CLASSICS



PACK INCLUDES:

- 1x AMIGA 500 PLUS £399.99
- BUILT-IN 18-KEY DRIVE FREE
- AG30 TV MODULATOR FREE
- THE SIMPSONS £24.99
- CAPTAIN PLANET & THE PLANETEERS £25.99
- LEMMINGS £25.99
- DELUXE PAINT II £79.99

PLUS! FREE FROM SILICA

- ZOOOL PACK £127.92
- PHOTON PAINT v2.0 £89.95
- GFA BASIC v3.5 £50.00

PACK VALUE: £824.88
PACK SAVING: £325.92
SILICA PRICE: £299.00



We are pleased to offer the original 1Mb Amiga 500 Plus (Kickstart/Workbench v2.04), including a built-in 18-key numeric keypad and Cartoon Classics software at the unbeatable price of only £299. The Amiga 500 Plus can be upgraded, using any of the hundreds of peripherals that are now available, which include the award winning range of GVP hard drives, GVP peripherals can also provide PC emulation, processor acceleration and extra hard drive storage space. There is also a wide range of expansions which give the A500 Plus higher resolutions and more colour and genlocking capabilities.

INCLUDES BUILT-IN 18-KEY NUMERIC KEYPAD

1Mb AMIGA 500 Plus CARTOON CLASSICS

£299
INC VAT - AMC 0592

AMIGA 600

AMIGA 600 COMPUTER WITH FREE! Lemmings & DELUXE PAINT III PLUS! FREE GIFTS FROM SILICA



The new Amiga 600 uses state-of-the-art surface mount technology, for maximum reliability and features a 3 1/2" floppy drive, mouse, TV modulator and smart card slot all as standard. The innovative smart card slot accepts games, ROM or RAM cards (from 1Mb up to 4Mb) and will take advantage of many future new developments. The very latest version of the operating system, Kickstart/Workbench v2.05 is used in the Amiga 600 and its enhanced chip set facilities include improved graphics resolution, increased genlock support and the facility for up to 2Mb of chip memory. The Amiga 600 is fully compatible with the A670 CD-ROM Drive and Interface which will give it access to a full range of CDTV titles and audio CDs. The Amiga 600 is available from Silica in several configurations including a special 2Mb RAM upgrade optional extra - see the chart below.

A600 + LEMMINGS + DPAINT III
£299
INC VAT - Ref: AMC 0666

NEW! AMIGA 600 PACKS

WILD, WEIRD & WICKED

EPIC 'HARD DRIVE' PACK



The Wild, The Weird and The Wicked (WWW) is the title of Commodore's new Amiga 600 games pack. Priced at £349, it comes complete with Amiga 600 computer and mouse, plus a range of high quality entertainment software. For pack contents, plus a list of the FREE gifts from Silica with every Amiga 600, see the chart on the right.

£349
INC VAT - AMC 0649

For the more serious user, the £499 Epic Language Pack is based around the A600HD, the A600 with 20Mb hard drive. It includes challenging adventure games and software for the linguistically minded! Details are shown on the chart on the right along with a list of the FREE gifts from Silica with every Amiga 600 purchased.

£499
INC VAT - AMC 0799

AMIGA 600 COMPUTER OPTIONS	NO HARD DRIVE		20Mb HARD DRIVE
	LEMMINGS	WWW PACK	EPIC PACK
• 1x AMIGA 600 + MOUSE, 3 1/2" Disk Drive, TV Modulator, Smart Card Slot	£299.99	£299.99	£299.99
• 20Mb HARD DISK - Very fast, mass storage for programs and data	£79.99	£79.99	£299.00
• DELUXE PAINT III - Award winning graphics and animation package	£25.99	£25.99	-
• LEMMINGS - Save the Lemmings as they drop into 100 screens of danger	-	£34.99	-
• MICROPROSE GRAND PRIX - Racing 5m with all the thrills & spills of the track	-	£25.99	-
• SILLY PUTTY - The pliable arcade game of immense playability	-	£25.99	-
• PUSH OVER - A game of puzzles. Can G.I. Ant save Colin Curly's Quavers?	-	-	£29.99
• EPIC - A Sci-Fi adventure. Can you guide a space fleet across the solar system?	-	-	£25.99
• ROME - Your goal is to become Emperor in this role playing adventure	-	-	£19.99
• MYTH - Can you stop the spread of evil and question the judgements of the gods?	-	-	£29.99
• TRIVIAL PURSUIT (in 3 languages) - The great trivia quiz game for the Amiga	-	-	-
• WORD PROCESSOR + DICTIONARY (in 3 languages) - For creating documents	-	-	-
• 1 YEAR ON-SITE WARRANTY	-	-	-
PLUS! - FREE FROM SILICA	-	-	-
• ZOOOL PACK - Four top Amiga titles - see panel above	£127.92	£127.92	£127.92
• PHOTON PAINT v2.0 - An art package with numerous features & special effects	£89.95	£89.95	£89.95
• GFA BASIC INTERPRETER v3.5 - A language for programmers of all levels	£50.00	£50.00	£50.00
TOTAL PACK VALUE:	£673.84	£734.82	£972.82
LESS PACK SAVING:	£374.84	£385.82	£473.82
SILICA PRICE:	£299	£349	£499
2Mb RAM PRICE OF UPGRADE TO 2Mb RAM WITH BATTERY BACKED CLOCK	+£45	+£45	+£45

ALL PRICES INCLUDE VAT - DELIVERY IS FREE OF CHARGE IN THE UK MAINLAND

SILICA SYSTEMS OFFER YOU

- **FREE OVERNIGHT DELIVERY:** On all hardware orders shipped in the UK mainland.
 - **TECHNICAL SUPPORT HELPLINE:** Team of technical experts at your service.
 - **PRICE MATCH:** We normally match competitors on a "Same product - Same price" basis.
 - **ESTABLISHED 14 YEARS:** Proven track record in professional computer sales.
 - **£12 MILLION TURNOVER (with 60 staff):** Solid, reliable and profitable.
 - **BUSINESS + EDUCATION + GOVERNMENT:** Volume discounts available 081-308 0888.
 - **SHOWROOMS:** Demonstration and training facilities at our London & Sidcup branches.
 - **THE FULL STOCK RANGE:** All of your requirements from one supplier.
 - **FREE CATALOGUES:** Will be mailed to you with offers + software and peripheral details.
 - **PAYMENT:** Major credit cards, cash, cheque or monthly terms.
- Before you decide when to buy your new Amiga computer, we suggest you think very carefully about WHERE you buy it. Consider what it will be like a few months after buying your Amiga, when you may require additional peripherals or software, or help and advice with your new purchase. And, will the company you buy from contact you with details of new products? At Silica Systems, we ensure that you will have nothing to worry about. We have been established for almost 14 years and, with our unrivalled experience and expertise, we can now claim to meet our customers' requirements with an understanding which is second to none. But don't just take our word for it. Complete and return the coupon now for our latest FREE literature and begin to experience the "Silica Systems Service".

MAIL ORDER HOTLINE **081-309 1111**

SILICA SYSTEMS

MAIL ORDER: 1-4 The Mews, Hatherley Rd, Sidcup, Kent, DA14 4DX Tel: 081-309 1111
 Order Lines Open: Mon-Sat 9.00am-6.30pm No Late Night Opening Fax No: 081-308 0608

LONDON SHOP: 52 Tottenham Court Road, London, W1P 0BA Tel: 071-580 4000
 Opening Hours: Mon-Sat 9.30am-6.00pm No Late Night Opening Fax No: 071-323 4737

LONDON SHOP: Selfridges (1st Floor), Oxford Street, London, W1A 1AB Tel: 071-629 1234
 Opening Hours: Mon-Fri 9.30am-7.00pm (Sat close 6.30pm) Late Night: Thursday - 6pm Extension: 3914

SIDCUP SHOP: 1-4 The Mews, Hatherley Rd, Sidcup, Kent, DA14 4DX Tel: 081-302 8811
 Opening Hours: Mon-Sat 9.00am-5.30pm Late Night: Friday - 7pm Fax No: 081-309 0017

ESSEX SHOP: Keddies (2nd Floor), High Street, Southend-on-Sea, Essex, SS1 1LA Tel: 0702 462426
 Opening Hours: Mon-Fri 9.30am-5.30pm (Sat 9.00am-4.00pm) No Late Night Opening Fax No: 0702 462363

To: Silica Systems, SUCRS 02 93 - 80 1-4 The Mews, Hatherley Rd, Sidcup, Kent, DA14 4DX

PLEASE SEND A 64 PAGE AMIGA COLOUR CATALOGUE

Mr/Mrs/Miss/Ms: Initials: Surname:

Company Name (if applicable):

Address:

Postcode:

Tel (Home): Tel (Work):

Which computer(s), if any, do you own?



A He won't be grinning if that whopping great ball and chain hits him.

ROBIN LEGEND QUEST

ISUI SILVER

Yo, ho, ho and a bottle of rum'. Or have I got that right? No, that's a pirate song. What did Robin Hood and his Merry Men sing anyway?

Whatever it was it must have been good 'cos they've gone down a storm in popular legend, not only here in Britain but all over the world. Especially the USA where Robin Hood movies have been big business for decades. This could be why Codemasters released Robin Hood Legend Quest first in America, on, of all things, the Nintendo Entertainment System.

The story of Robin is well

known. He was an impoverished, dispossessed, Saxon Lord who, maddened at the wealth of the church and the Norman aristocracy, embarked on a 'rob the rich to feed the poor' policy the like of which has never been seen since. (Though many since have robbed the poor to feed the rich - OO-er, SU's social comment of the year!) No one really knows whether Robin was very successful, in fact no one really knows whether he even existed at all but it's a great story and who am I to buck it.

In this game Robin Hood must do the two things that matter most to him. (A) Rob the rich to feed the poor by raiding the Sheriff of Nottingham's castle, and (B) Rescue his love interest, the gorgeous Maid Marian (or Marion as the Americans insist on calling her even though it's a boys name) from the very same fortified abode.

It's not easy though. The castle is gigantic with lots of battlements, dungeons, kitchens,



bedrooms, torture chambers and other less identifiable (and undesirable) rooms to explore. Plus there's the usual complement of guards, midgets and orcs who may not really be all that bad off the job but are certainly being paid to stink at the moment by the evil Sheriff Of Nottingham.

Our little Robin is equipped with a bow and arrow and a very nimble pair of legs. He must dispose of those guards that are disposable of by arrow and avoid those that are just too tough for words by waiting out of

their range and then running for it when they turn their backs.

Dotted around the keep are extra lives and treasure. The treasure consists of chests (not of the hairy type you understand), crowns, diamonds, rubies, shields and goblets. All are objects one would expect to find in a medieval castle and all



Alan

I've seen Robin Hood Legend Quest on other formats and to be honest it just doesn't look like a Codies title. No offense meant here, it's just completely different to their normal fare. One thing's for sure though it's a very good value, playable game.



Watch the lion's head.



A Go forward merry man.



A That little guy's mean!

WHERE HAVE ALL THOSE MERRY MEN GONE?

Robin Hood used to have a well known band of helpers, his famous Merry Men, but unfortunately none of them are at his side to help him in this quest. Why?

Little John: Little John is perhaps Robin's most famous friend and follower and in real life (or legend anyway) was anything but small. However during this game he was apparently completing a Phd in aerodynamics and astrophysics at Nottingham university and was unavailable for action or comment.

Friar Tuck: Friar Tuck, Marian's confessor and Robin's well known religious companion was at a health farm in Berkshire trying to lose some weight for a new film role. He's due to star in a biography of the famous comedian Oliver Hardy, part of the Laurel and Hardy duo, a new film by Sir Richard Attenborough.

Alan-A-Dale: Young Al, better known as Robin's minstrel was unavailable because he's just joined top rock group Motorhead playing electric mandolin. 'It's all because of the leather gear and the groupies mahn' Catch him on their new album 'Green Sleeves On My Leather Biker Jacket From Hell'. MC, CD, LP.

Will Scarlet: Will has gone into the fashion business having been spotted by Yves Saint Laurent in Paris wearing a dashing red number with a saffron silk shirt and a thirties style baggy tweed hat. He's now a top designer for YSL and you can expect to see his spring range in the shops soon.

ROBIN HOOD LEGEND QUEST

GAME: Robin Hood Legend Quest
 LABEL: Codemasters
 MEMORY: 48K/128K
 TAPE: £3.99

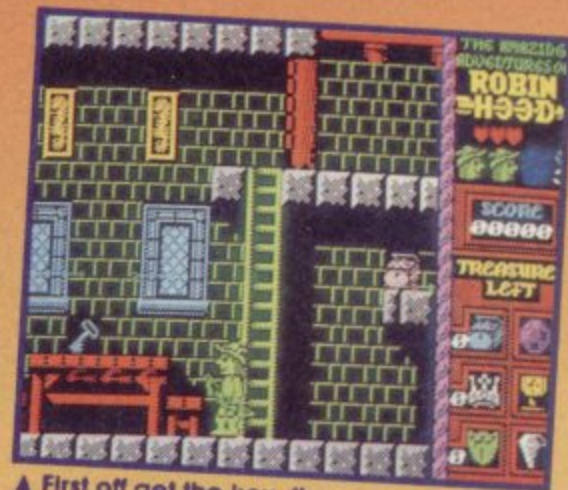

▲ First off get the key, then mosey back over to the treasure chest.

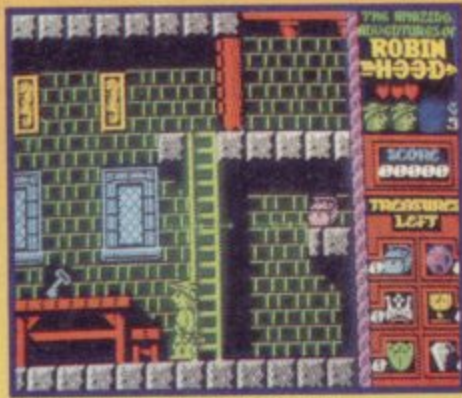

(in hearts) how many life points Rob has and also indicates how much of the treasure you have recovered so far. Although Robin starts off with three life points more are dotted around the castle and if you manage to collect a further three you will automatically get an extra life. Also, to finish the game you'll need eight of each item of treasure.

verting a console game to Speccy when Nintendo users now have Dizzy to play with. Robin Hood isn't a difficult game but it's very refreshing and enjoyable nonetheless. Worth a look.

Scores

GRAPHICS	90
SOUND	84
PLAYABILITY	89
LASTABILITY	82

OVERALL 89%
 Big Al Dykes

Robin Hood is a delightful game and an excellent conversion of the Nintendo original. There is a lot of sprite detail and absolutely heaps of playability. It may not last forever but it's well worth getting hold of.

are also highly redeemable by the poor for food. His final task is to rescue Marian.

Robin Hood Legend Quest is extremely well put together and beautiful to look at. It's basically a horizontally scrolling platform game and the main screen consists of the central playing area, to the right of which is the life and icon panel. This panel shows

The graphics are colourful and superbly animated. If you leave Robin alone for a moment to think he turns towards you and smiles and the sequence where he aims his bow, draws it and fires is excellent. Control is a little soft but not annoyingly so and it is easy to get the main sprite to respond to your commands.

Overall Robin Hood is a high quality title that deserves to do well. The quality of its graphics and playability is undisputable and it's nice to see Codies con-

GETTING AROUND THE CASTLE



Robin Hood has a big job on his hands trying to find Maid Marian in the Sheriff of Nottingham's castle. He must face guards, obstacles, arrows and lava if he is to rescue his true love.

Luckily there are certain ways and means of avoiding trouble and defeating these obstacles. For a start he can jump over some offensive items or duck under others. There are also objects like trampolines (above) and moving platforms to get him from place to place but getting on and off them at the right time is not always easy. The best advice is to take things slowly, don't go rushing into situations. You only have three lives (unless you gather some more) so don't waste them.



WRESTLING SUPERSTARS

GAME: Wrestling Superstars
LABEL: Codemasters
MEMORY: 48K/128K
TAPE: £3.99

Aaaaaannnnndddd now, weighing in at an unfeasibly large amount, it's the celtic crusher, BiiiiiGGGG Al' Dykessss! (fanfare, cheers, wolf whistles). And his opponent tonight, all the way from Brum, Garrrrthy 'Stubble' Sump-terrrrrrrrrrrrr! (Boo, hiss, belch).

Ah yes, the SU Towers office Christmas party was a wonderful affair. All manner of cocktails and beers (non-alcoholic of course) were drunk and all sorts of boisterous male bonding type pranks were engaged in, not to mention the all the female bonding buffoonery! But then we had



Scores

GRAPHICS	78
SOUND	71
PLAYABILITY	81
LASTABILITY	59

OVERALL 73%
Big Al Dykes

Wrestling Superstars isn't a bad wrestling simulation, there are as many moves and opponents as WWF or Tag Team, but it doesn't have the excitement of the former or the originality of the tag team option in the latter. If you really want another wrestling game get it but don't expect it to last more than a few hours, if that.

feat. The first two, Skullbasher Bob and Knuckle Buster Nick are really easy to thrash. However by the time you get to The Masked Marauder your arms begin to ache and the going gets tougher. Still, if you're determined, you'll soon finish him off along with the Golden Guy, and the game ends rather too quickly. Though this could also have been said about WWF or Tag Team.

10



THIS IS AMAZING!
 THE DARLING DUDE UINS!
 THE ROUND!

A No it's not blinking amazing. I happen to be very good!



A Oh oh, Knucklebuster Nick looks as though he's getting mad.

Death approaches in the form of the Masked Marauder. Keep away!



A And yes, I thought so. That must be a triple swirl murder throw.

The Masked Marauder pins him down. Get off your hairy gill!

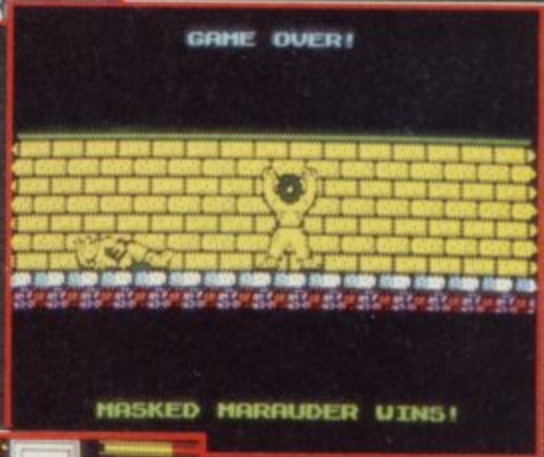

GAME OVER!
 MASKED MARAUDER UINS!

A Beaten at last by an idiot with a mask. Oh the shame of it all.



Steve

No where near as exciting as WWF, but then it's not a full price title. I can't help feeling that this game is just cashing in on the success of the other wrestling games, 'cos there's nothing new or original about it except the wrestling characters themselves.



a lot of practice beforehand 'cos good old Codies sent us Wrestling Superstars along with a couple of bottles of pop and a note saying 'this is good'.

Basically Wrestling Superstars looks a lot like every other wrestling game we've ever reviewed. There's a ring, there's some wrestlers, there's a clock, and there's a lot of moves. There's also no surprises and anyone who's layed their grubby, sweaty paws on WWF Wrestlemania or Tag Team Wrestling will not be in the dark



as far as the fighting goes. By pressing fire you can thump, pushing forward and pressing fire enables you to kick, pushing up and pressing fire does a knee jump and you can also bounce off the ropes and jump kick, swing your opponents in the air and throw them or pin them down. There's no lack of moves but there is a lack of real challenge, certainly in the first two fighters.

You play the part of The Darling Dude and there are four other really nasty wrestlers to de-

The quality of the graphics is fairly good, nothing awe inspiring though. Basically black sprite outlines drawn on blue with a bit of black, white, yellow and red around the outside and in the power gauges, what more can I say. The main sprites move quickly and look reasonably good though their thumps and kicks just don't look vicious enough.

Overall Wrestling Superstars is an amusing wrestling sim that differs little from its predecessors, except for its lack of originality. If you really need to exercise your joystick hand then it's ideal (it'll wear it out) but for reasons of lastability I wonder if this game is really worth it.

SUPERMART SUPERMART

SINCLAIR POWER SUPPLY UNITS



ALL BRAND NEW & GUARANTEED

ALL PRICES INCLUDE V.A.T
PLEASE SEND 3.00 P&P

SPEC 48K, 48K+, 128K & 128+2 GREY 9.95

SPEC +2 (BLK) +3 & 6L 14.95

(TRADE QTY DISCOUNTS UP TO 50%)

BROTHER POWER SUPPLY UNITS

6 VOLTS 2AMPS 6.95



J.R.C. CAMERA REPAIRS
2 FORGE COTTAGE
EWELME OXON OX10 6HG

TEL 0491-34403

PRINTED BY JAMES GRAPHICS
TEL 0491-81294

SPECTRUM UTILITIES

THE "HACKPACK" - £9.99

The ultimate hacking package created by a professional hacker. Six programs which enable you to hack or crack any protection on any game. Find infinite lives, disassemble code - the scope is limitless.

Complete with instruction booklet containing hints 'n' tips.

NEW!! GAMES DESIGNER - £19.99 NEW!!

A comprehensive guide to writing your own BASIC/machine code arcade games. Includes a complete free game showing step by step how it was produced. This bumper package also includes an extended machine code toolkit.

PROGRAM PROJECT - £5.99

Expert routines to protect your programs and fight piracy.

CHARACTER SET COLLECTION - £5.99

Twenty fonts for use in your own programs - from Sci-Fi to Gothic.

VIDEOMASTER - £14.99

Add text, borders and graphics to your own home video recordings.

SPEEDY LOAD - £5.99

Convert your programs to turbo load like professional programs

INTERRUPT SOUND EFFECTS - £3.99

Create amazing interrupt driven sound effects that run without stopping program execution.

DRUM BEAT MACHINE - £3.99

Add your own rhythms to your programs with a snare and bass drum.

GAMES AID - £3.99

Character font creator, tips and machine code toolkit of routines.

POKES GALORE - £3.99 Cheats for 80 games on tape.

MESSAGE SCROLLER - £2.99 Scroll messages in your programs.

DOUBLE HEIGHT PRINT - £2.99

SPI DROID - £2.99 LASER WAR - £2.99

* FREE CD Single with all orders over £15.00 *

Send two First Class stamps for FREE Catalogue

Please add 50p P&P unless ordering more than one program

SIGMASOFT Dept SU, 8 Pine Dale Rainford
Merseyside, W11 8DP

Multiface. BUY NOW! IT'S BYE NOW...

When the **MULTIFACE** was launched in 1984, it was an outright winner. No one has ever come up with such a powerful, useful add-on. Labeled the *ESSENTIAL SPECTRUM COMPANION*, this **MULTI**purpose inter**FACE** proved to be an absolute Godsend for the Spectrum users.

HISTORY?

It all started with the **MULTIFACE ONE** for the original 48K Spectrum, quickly followed by the **MULTIFACE 128** for Spectrum 48, 128 and +2. Remember the *microdrives*, *wafadrives* and *add-on disk drives*? Suddenly the loading from these took **seconds** rather than minutes. Except that there was not much to load - practically nothing had ever been released on cartridges or disks and there was no facility to transfer tapes onto those great new devices. This is where the **MULTIFACE** saved everything, literally. The black magic box could stop anything any time and **SAVE** it to *disk/cartridge/wafer/tape*. When the Speccy+3 came with a built-in drive, it was left to the **MULTIFACE 3** to transfer all to disks - and to perform other miracles (Multiface 3 is also needed for the *black Spectrum +2A/+2B*).

So, in case you just came from Mars, what does a Multiface do? First, it sits at the back of your Speccy, its magic button always **READY**. It has its own **ROM/RAM**, so it doesn't take up any Speccy RAM and needs no extra software. It comes with a full manual, but you will not need it, as the Multiface is fully **MENU-DRIVEN**.

ACTION!

Once in action, it freezes everything and it displays its own menu. You can, say, **SAVE** the program, return to it and continue. If you loose your game, just re-load from where you saved last and play from there again! No need to go back to start all the time. Even better, with the **MULTIFACE** you can **POKE** all those infinite lives, ammo, etc., that you read in the magazines, and you will never loose. Each Multiface also comes with a built-in **TOOLKIT** that lets you inspect/alter/dump Speccy RAM.. Many top programs were written with the aid of the **TOOLKIT** and the extra 8K RAM. And do you like the **screen shots** in this magazine?

They are all produced using the **MULTIFACE!**

When we announced earlier that we were to pull out of the 8-bit market, the surge of interest in the **MULTIFACE** was such, that we had to make many more. And not just the Multiface - we also have the best ever printer interface - the **MULTIPRINT** (not for Speccy+3 or +2AB) and the only digitizer - the **VIDEOFACE** (for any Spectrum). Our software includes the unlimited life finder **LIFEGUARD**, the **GENIE** disassembler, and the **MUSIC TYPEWRITER**. Please send a SAE for full information.

HURRY!

As this goes to press, we still carry all items, but some in low quantities only. Once we sell the stock of **MULTIPRINTS**, **VIDEOFACES** and **MULTIFACE ONES**, we have no plans to manufacture those again. They are a terrific value, in fact more for the *customer* than for the *manufacturer*... So quite simply, **HURRY!** As for the **Multiface 3 & 128**, we plan to go on making them to meet the demand. In any case we will only accept orders when we can supply the goods and we give a **full guarantee**. Plus we still offer now up to **£15 OFF!** mail orders!

You MUST NOT use our products to copy, reproduce or infringe in any way whatsoever any copyright material without the permission of the copyright owner. We do neither condone nor authorise the use of our products for the reproduction of copyright material - to do so is **ILLEGAL!**

All prices are already discounted and apply to Mail Orders to 2.3.1993 only.

I enclose a Cheque/Postal Order/Cash plus P&P for £.....

or debit my Access/Visa

Name..... Card Exp.....

Address.....

P&P UK & Europe £ 2.00 <input type="checkbox"/>	P&P OVERSEAS £ 3.00 <input type="checkbox"/>
MULTIFACE ONE FINISHED	GENIE 1/128 (NOT 3) £ 6.95 <input type="checkbox"/>
MULTIFACE 128 £ 29.95 <input type="checkbox"/>	LIFEGUARD £ 6.95 <input type="checkbox"/>
MULTIFACE 3 £ 29.95 <input type="checkbox"/>	Multiface 3+ thru port £ 34.95 <input type="checkbox"/>
MULTIPRINT £ 29.95 <input type="checkbox"/>	WRIGGLER £ 2.95 <input type="checkbox"/>
VIDEOFACE £ 29.95 <input type="checkbox"/>	Spectrum +3 Disks £ 2.95 <input type="checkbox"/>
MUSIC Typewriter £ 5.95 <input type="checkbox"/>	Spectrum +3 Tape lead £ 2.95 <input type="checkbox"/>

ROMANTIC ROBOT, 54 Deanscroft Ave, London NW9 8EN ☎ 24 hrs 081-200 8870

HACKING SQUAD



Hi folks it's your old mate Garth here with some cracking top hints and tips for your fave games. This month I've adopted a new and novel approach to putting the world renowned Hacking Squad together... I sat down and opened some letters, looked at some games and chanted a mystical enigma, passed on to me by the Sorceress, which enables you to write four entire pages without actually touching a pen or a computer keyboard. Big Al' didn't believe me at first but as it all appeared before his eyes he was filled with wonder and had to nip down 'the boozier for a quick pint of Pepsi before he passed out. Anyway, enough idle boasting, on with the show...

Spellbound Dizzy

FINAL PART NEXT MONTH!

12

Douglas Bistal is a hero. Not only is the man brave enough to hand his homework in on time, but also he's not going to be afraid of the bulging Hacking Squad box of goodies that will come winging through his letterbox unannounced containing some nifty games. Having served Hacking Squad this month, he'll be enjoying the benefits for a couple of month's to come! Well done lad! What did he do to deserve these favours I hear you ask... Well he sent in a full and detailed solution to Spellbound Dizzy, the first part of which we're giving to you now, while the second part will wing its way to you next month.

Part 1

There's no mistaking that Codemasters probably produce some of the best software available for the Spectrum so it's little surprise that we get enough egg-related envelopes to make the worlds largest omelette. Without cracking any more egg-stremely bad yolks, here's part one of the solution from Douglas...

To start with, head left, jump over mushroom and walk into the deep pit, so you land on the trampette. Wait till you've finished bouncing, then get off. Pick up the trampette, and take it to the left hand side of the pit. Drop it roughly where the fruit is, then get on it, and by keeping the Jump key held down, bounce out of the left hand side of the pit, and walk left to the sandstone quarry.

Jump over the mushroom, and collect a rock. Now go back right, walk into the pit, and if you placed the trampette correctly, you won't get hurt. Move the trampette back to the right-hand side of the pit, and bounce on it to return to the starting screen.

You need another rock, though, and since rocks break if you drop them on the floor, you need to jump onto the mushroom here. Jump to the right, and you'll land on a cloud, where you can safely drop the rock.

Now go back to the quarry again, and fetch a second rock, then return to the cloud above the starting screen, and collect the rock you left there.

Return to ground level, and from the starting screen, head right to the windy shaft. The rocks serve to weigh you down enough to descend quite a way: You want the second exit on the left, which leads to Theo's Grotto.

If you haven't talked to Theo yet, then you should do so. Otherwise, you'll want to take the upper passage left from the crystal tree, then jump up at the end, and left again to Dylan's hole.

You can't talk to Dylan yet, because he's stuck underground, but if you drop one of the rocks, you'll be able to pick up the hammer that's in this room. Now return to the windy shaft.

Because you've only got one rock, you get carried upwards, and you want the exit on your right: the mine shaft. Go in, and follow the railway track right, to where the track is broken.

Fix the track with the hammer, dump the other rock, and walk back to the windy shaft, and thus to the surface. Dump the hammer in the starting room.

Right, now go left to the quarry again, and pick up one rock. Then, instead of returning straight away, use the mushroom in the quarry to jump right, into some clouds, and from there go left, via some more clouds, to the edge of a vast lake.

Now whatever you do, DON'T FALL IN!

SOLUTION

You need to ride Wally the Whale across the lake, and get the brake shoe from the other side. Then return, go across the clouds, and land neatly on the trampette, in the pit.

Drop the brake while you move the trampette to the other end of the pit, then pick it up again, and take the brake and the rock to the windy shaft.

One rock is enough to get you back to the mining shaft, and once there you MUST drop the rock, before attaching the brake shoe to the cart, and getting in...

One quick Indiana-Jones impersonation later, you should be at the very end of the line. Now go right and up, and pick up the bag (at last, you can carry more than two objects!).

Then go up to the ore crushers, and pluck up enough courage to walk left, straight through them and pick up the megaphone. Then continue left, over the rickety bridge, and collect the shamrock, then down, back to the mine shaft. Now walk left, back to the windy shaft, return to the surface, and dump the shamrock and megaphone in the starting screen.

Next: You need three rocks. Fortunately, you can collect them all in one journey. Pick up the shamrock, and take your heavy load to the windy shaft, and go down the the four-way junction with green walls. Go right, run over the man-eating plant, and talk to the leprechaun. Give him the shamrock, and pick up the talisman he'll give you in return.

Some of you still write in telling me that my pokes are no good. Unfortunately, most of your rebellious ravings are due to the fact that you are still missing something... A multiface.

Unless you have one of these useful little widgets to wedge into the back of your Speccy, you just can't benefit from the Hacking Squad's pokes - it's like trying to clean a tiolet with a skunk hair tiolet brush. (Peeewwwwh!)



This little box of tomfoolery will cost you about 30.00 from Romantic Robot on 081 200 8870 - A Hacker just isn't dressed without one!

Garth's Big POKEs



STREET FIGHTER

41740,24
41336,255

TARZAN
51013,0

Immune
Never loose
a fight

Time

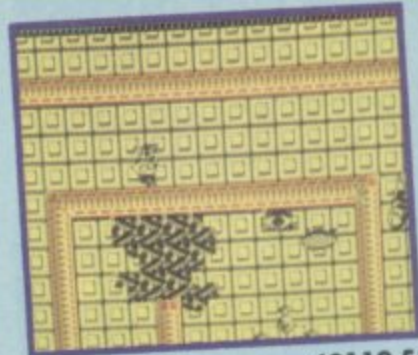

GOTHIK

Lives 42110,58
43834,58

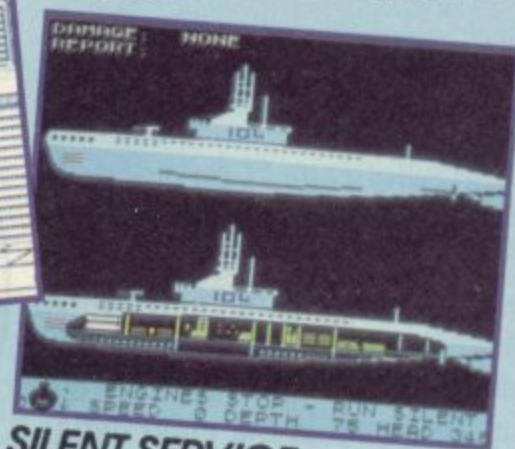

SILENT SERVICE

25991,255
34202,19

Lots of torpedoes
Extra lives

ON CITY

Now go left, and cross the windy shaft to the scales. Drop a rock on the Right pan of the scales, and then go down the hole under the left pan. When you hit bottom, go left, avoid the dangerous drips, and talk to Grand-Dizzy. Pick up the ear trumpet, and leave the dank room using the mushroom provided.

Drop another rock (leaving one), and return to the windy shaft. Keep to the left wall, and leave the shaft at Theo's exit (the second on the left), and drop the ear trumpet. Now cross the windy shaft to the mine shaft. KEEPING your one rock this time, get in the cart again.

This time, instead of flying effortlessly over the chasm, the cart will crash into the reservoir wall, and You'll fall into some potentially deadly water. However, you've just got time to run right: Since you're carrying the talisman, the beast will remain passive, and you can jump over it and get up to the air... Now go right to the beast's lair, and avoiding the shark, collect the aqualung.

Keep hold of the talisman, and go out past the beast. Dump the talisman in the reservoir, and continue left to the mine shaft, avoiding the assorted marine life. Drop the rock that you've been carrying, and return to the surface with the aqualung.

Right, so now you can safely explore all the watery bits of the map next month!

THE LOCATIONS OF THE STARS

You have to constantly collect stars to get through Spellbound Dizzy so just to help, here are all their location as well.

First: The magic stars. There are fourty of them altogether, five for each of the yok-folk, five for Pogie, five for Theo, and none for poor little you:-

There's one at the top of the windy shaft, and one on the cloud above the starting screen.

There's one on a cloud to the left of the fireflies, and another on the screen below this

There's one in the quarry, behind a tuft of grass, one in the clouds above the quarry, and one above the lake that you can pick up whilst standing on the whale.

There's one at the top of the lake-side cliff-top, and two in the woody grove, behind a tuft of grass, and behind some leaves.

Then there are two in the clouds above the woody grove: The first takes quite a stretch, and the others are above Denzil.

There are three in the watery passage: One right at the very start of it, one in a chamber in its roof that you'll need flippers to get at, and the third behind some seaweed almost at the far end.

There's one in the bear's cozy room, by the windy shaft.

There's one down the mining shaft, near the mushroom. one in the rockfall at the far end, and one on the rocks near the ore crushers. Then there's one behind the chain of the right-hand ore crusher. There are two hidden behind railings on the rickety bridge: In addition to the stars, behind the railings is a mushroom, which gives access to a further three stars once you've got past some nasty drips.

Next there's one in the water in the spooky cave, one on the reservoir floor, and one in the beast's lair, behind the shark.

There's one on the crystal tree: behind a crystal, and one in Theo's grotto, behind the left-most railing.

There's one in the substation, at the extreme right, and three in the pumping station: One to the left of the reserve tank, that you can't reach till you've flooded the chamber, one behind a railing on the platform above the oil drums, and one on the floor at the left hand end.

There's one inside the spare ore-crusher: To get it, you'll need to jump into it from quite a distance!

Finally there are five at the bottom of the shaft: one next to the Leprechaun, one by the plant's roots, behind some seaweed, two on the floor of the flooded chamber (one of which is behind the right-most clump of seaweed), and the last one in the sunken shed.

VITAL OBJECTS

The three vital objects which you need to escape from the Mystic Kingdom yourself are in three hidden rooms:

As well as Theo's piece of string... There's some sticky tape in a room at the far end of the watery passage (which you'll need the flippers and the aqualung to get at).

There are some thin sticks in a room past Dylan's hole. And finally there's some pretty cloth in a room to the right of the pumping station. Again, you'll need flippers and aqualung to get into this room, but that's not the end of it...

This room is a nasty illusory room, and the cloth is behind one of the wall panels: The route you'll need is down, right, jump left, jump up-and right. Pick up the wall panel and cloth. Walk left, jump left, jump right, and finally a couple of carefully placed jumps left to the exit.

HACKING SQUAD

SUPER FRUIT

CHERRY	POUND	LEMON	= 2 Nudges
PEAR	ORANGE	CHERRY	
MELON	PLUM	ORANGE	
MELON	PEAR	PLUM	
PLUM	ORANGE	PEAR	= 4 Nudges
APPLE	LEMON	PEAR	
CHERRY	ORANGE	CHERRY	= 6 Nudges

Millar Crawford age 11 on the Isle Of Arran (wow!) in Scotland was obviously well impressed with Novembers Great 8 'cos he not only sent in the excellent map below but he also included some hints for Fruit Machine. This map is the most definitive I've seen on Gunpowder Treason And Plot so well done that man.

GUNPOWDER

14

WHEN YOU GO LEFT IN THIS ROOM YOU ARE AT THE CAKESHOP

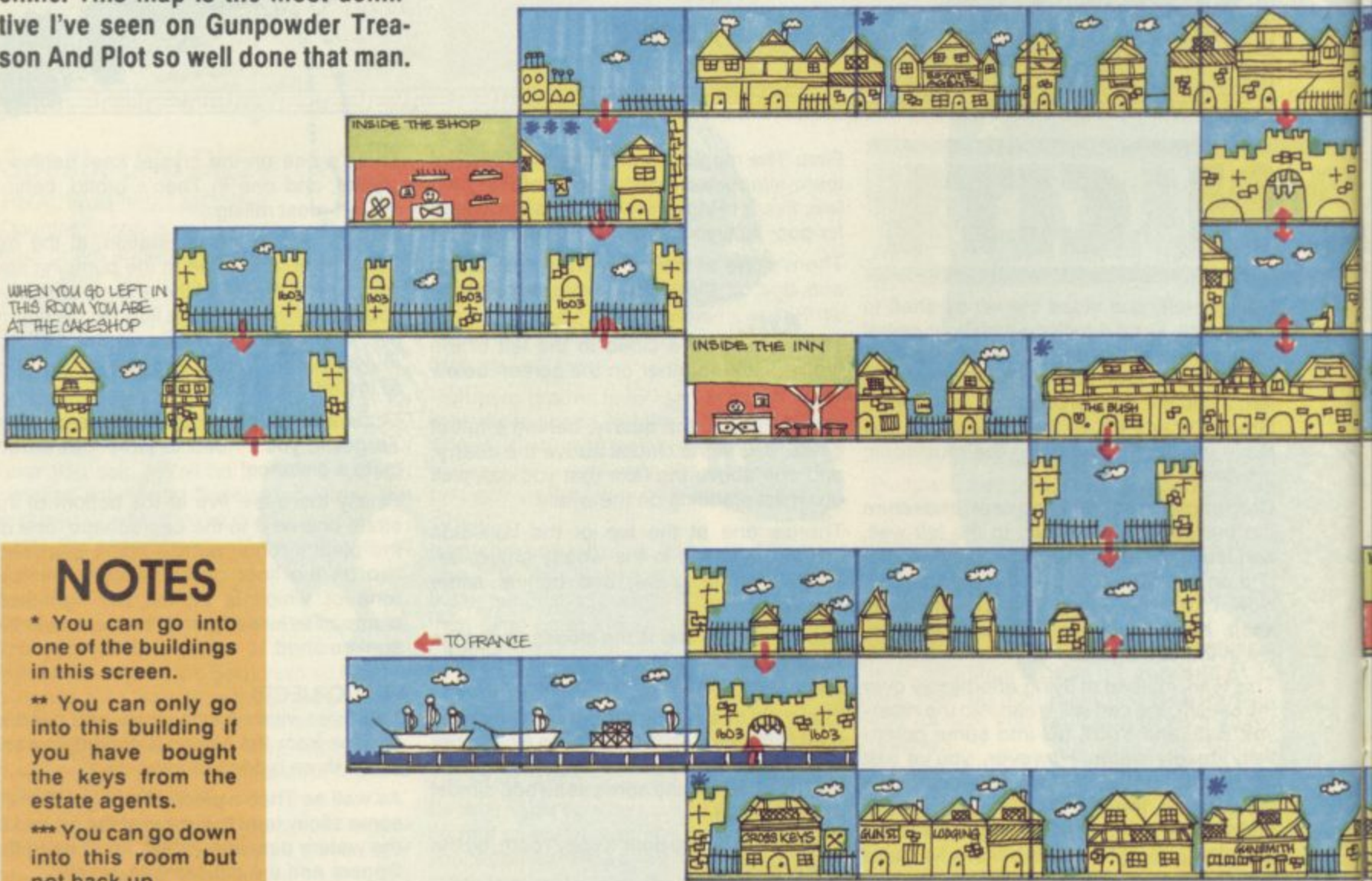

NOTES

- * You can go into one of the buildings in this screen.
- ** You can only go into this building if you have bought the keys from the estate agents.
- *** You can go down into this room but not back up.

THE ROOM BELOW THE ROOM BESIDE THE STORE



INSIDE THE CHURCH

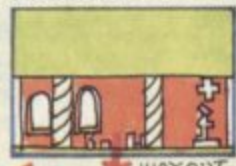

WAY OUT
SECRET PASSAGE TO INSIDE HOUSE ON START SECTION

INSIDE CROSSKEYS'



INSIDE GUNSMITH



WAY OUT

INSIDE CAKE SHOP



WAY OUT

IT MACHINE

HACKING SQUAD

CHERRY	PLUM	MELON	= Coin climb bonus game
PEAR	GRAPE	LEMON	
ORANGE	MELON	LEMON	
APPLE	PLUM	GRAPE	
POUND	MELON	GRAPE	= Money spin bonus game
POUND	CHERRY	PEAR	
PLUM	POUND	LEMON	
ORANGE	APPLE	POUND	

TREASON & PLOT

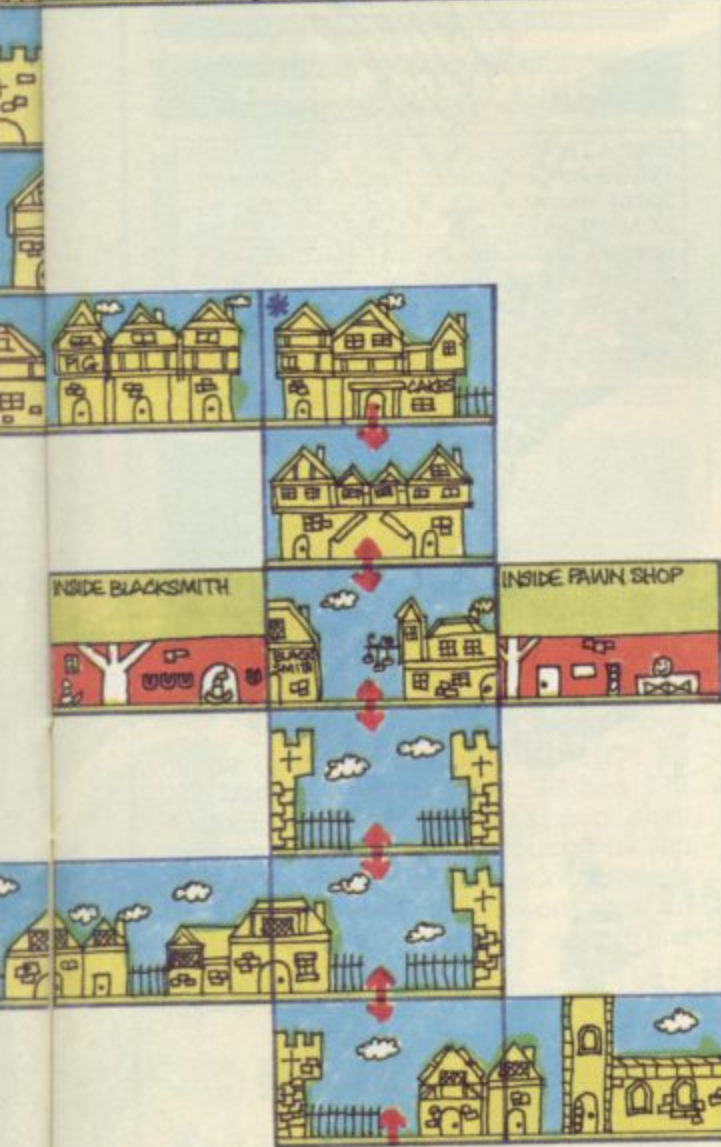
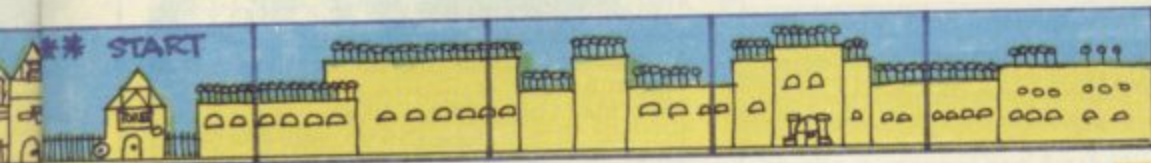

KEY

- Keys to the house on the start screen
- Vaccine
- Fuse Wire
- Candle
- Gunpowder
- You can go up a screen
- You can go down a screen

COST OF ITEMS

ITEM:	LOCATION:	COST:
Ale	The bush	1 Coin
House	Estate Agent	4 Coins
Vaccine	Shop marked X	2 Coins
Bun	Cake shop	3 Coins
Ale	The inn	3 Coins
Candle	Blacksmith	2 Coins
Gunpowder	Gunsmith	3 Coins
Ale	Cross Keys	4 Coins
Fusewire	Store	1 Coin
Ale	Shop with lion flag	2 Coins

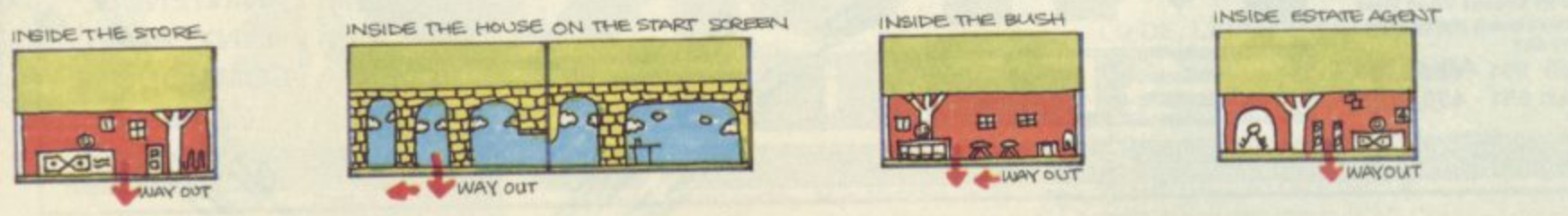

LOOK NO FURTHER!

Software

Afro Kit (Spectrum)	£4.99
Ball-Blazer	£1.99
Cartoon Collection	£8.99
Chain Reaction	£2.99
Chase HQ	£3.99
Colossus Chess 4	£9.95
Count with Oliver (Educational)	£10.99
Castles and Clowns (Educational)	£8.95
Euro Superleague +3	£6.99
Football Director +3	£17.99
Forgotten Worlds	£3.99
Funschool 2 (6-8 yrs)+3	£13.99
Funschool 2 (over 8) +3	£12.99
Funschool 2 (under 6)+3	£12.95
Giddy Game Show	£9.99
Hotline	£7.99
Look Sharp (Educational)	£9.99
Mega Apocalypse	£3.99
Ninja Remix	£8.99
Outrun	£3.99
Rigels Revenge	£1.99
Snapple Hopper (Educ)	£8.95
Technocop	£3.99
Terminator 2+3	£13.99
The Games	£3.99
Turtles	£8.95
Uridium	£2.99
Winter Games	£3.99
Zenon +3	£6.99

OVER 2000 DIFFERENT
ITEMS IN STOCK

Computer Package Deals and Accessories

Spectrum Plus 3 Computer	£119.95
Spectrum Plus 2 Computer	£99.95
Sega Megadrive plus 3 Games	159.00
Datacorder with +3 or 48/128 lead	£24.95
Spectrum +3 Cassette Lead	£3.99
48/128 Cassette Lead	£2.99
Head Alignment Kit (Spec)	£9.95
Head Cleaner and Fluid	£5.99

Joysticks and Interfaces

Kempston Joystick Interface	£12.95
Cheetah Star Probe	£12.50
Spectrum +2 Joystick Adapter	£5.99
Kempston +2/+3 Joystick Interface	£22.95
Quickshot Apache	£7.95
Konix Navigator	£14.50
Quickshot Python	£10.95

Graphics and Sound

Trojan Light Pen 48K	£22.95
Trojan +2 Lightpen (please specify +2/+2A)	£22.95
Trojan +3 Lightpen	£22.95
Spectrum colour printer DriverCassette £19.95...Disk £24.95	
Ram Music Machine	£49.95
Advanced Art Studio (128)	£24.95
Art Studio	£14.95
Date! Genius, Mouse & Art Studio (+3 version inc. Artist II)	£49.95
Artist II +3	£19.95

Back-up Devices

Multiface 1	£39.95
Multiface 48/128	£44.95
Multiface 3 Thru-port	£49.95

Protective Covers (All covers stocked - call us)

Spectrum Plus	£5.95
Spectrum ZX	£5.95
Spectrum Plus 2/3	£6.95
DMP 2000/3000/2160/3160 Printers	£7.95

Utilities

Hisoft Devpack +3	£17.95
Hisoft Basic +3	£26.95
Hisoft C +3	£27.00
Hisoft Pascal +3	£33.00
Hisoft Devpack 48/128	£13.95
Hisoft Basic 48/128	£22.95
Hisoft C 48/128	£23.00
Hisoft Pascal 48/128	£23.00
Masterfile +3	£26.95
Tasword 2 48k	£12.90
Tasword 3 (Microdrive)	£15.50
Tasword +2	£19.95
Tascal +3	£24.95
Tasprint +3	£19.95
Tascal (128/+2)	£19.95
Tasword +3	£24.95
Tas Spell +3	£24.95
Data Genie	£6.95
Genie 1 128 (for Multiface)	£9.95
+80 Stock Manager	£9.95
+80 Address Manager	£6.95
+80 V.A.T Manager	£6.95

Education

(FULL CATALOGUE ON REQUEST)

Disk Drives & Accessories

Plus D Disk Drive Interface	£69.95
Plus D + 3.5" Drive	£169.95
3.5" Disk Cleaner	£6.99
3" Disk Cleaner	£6.99
Microdrive Extension Cable	£9.95
10 CF2 3" Maxell disks	£19.95
10 TDK 3.5" DSDD	£9.99
+3,+2 or +2A Scart Monitor Lead	£11.95
TV/Computer Lead	£2.50
Bulk 3" CF2 Mansell 20 for	£22.00

Printers/Interfaces

Citizen 120D+ inc +3/+2A Lead	£149.00
Star LC200 Colour	£249.00
+3/+2A Printer Lead	£11.95
Multiprint by Romantic Robot (works as Kempston 'E')	£43.95
ZX Paper 5 Rolls	£19.95
Alphacom 32/Timex Thermal paper 5 Rolls	£11.95
Spectrum Colour Printer DriverTape £19.95...Disk £24.95	

Spares and Repairs

Spec 48 Power Supply	£13.95
128/+2 Power Supply	£24.95
Spec+ Membrane	£11.95
ZX Membrane	£7.95
Spec +2 Repair	£34.95
ZX Spec Repair	£29.95
4164 Mem Chips	£4.99
4116	£4.99
Spectrum +2A/+3 Power Supply	£24.95

FREE POSTERS & KEYRING

with each purchase of £10
WHILE STOCKS LAST

CHEQUE GUARANTEE NUMBER MUST BE
WRITTEN ON THE BACK OF ALL CHEQUES TO
AVOID DELAY.

UK POSTAGE AND PACKING. Items under
£50 add £2. Items under £100 add £5.
Items over £100 add £10 for Group 4
courier including delivery the day after
despatch. Overseas customers (Europe);
full price shown will normally cover carriage
and free tax. Non-Europe add 5% to total.

Microsnips(Satellite) Ltd. T/A Microsnips

**BIRKENHEAD
MAIL ORDER
& PERSONAL
CALLERS**

25-29 Grange Road West
Birkenhead, Merseyside
L41 4BY

Tel: 051 - 650 0500
Fax: 051 - 650 0506

MICRO SNIPS

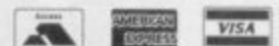

ALSO SEGA,
NINTENDO,
LYNX, ATARI,
COMMODORE,
GAMEBOY

SPECMAN

Hey folks, thanks, I mean wow, I've been inundated with letters and Christmas cards and new year best wishes cards and all sorts of things. I'm famous. But then I know a lot so why not? Keep those questions coming in...

GIVE US A BREAK

Dear Specman, I read in an issue of Crash magazine, on their Tech Talk page, that it is not possible to disable the break key in programs but only to crash the Spectrum if it's pressed. However most if not all of the games I own disable the break key. How do the programmers do it.
Steven Bassett, Birmingham.

Well, I did cover this in a previous column but I'll go through it again to tie up any loose ends. Your Spectrum, when running a basic program, calls up a routine in Spectrum ROM to check for the Break key being pressed. This is requested and carried out 50 times a second. We can actually disable this though by having the machine report an error whenever Break is pressed. By POKEing the error routine in the system variables to a daft value it causes a crash. Try POKE 23613,0 : POKE 23614,0 : LOAD "", press Enter and hold down Break. It should reset. Now 99 percent of games are written in machine code. If a programmer wishes the Break key to be scanned then he will put in a routine with which to do it. Because he is not using the Spectrum's ROM the break key will not return him back to basic with any error reports. Also, in order for the Break key to be scanned the request to scan the key i.e. the interrupts must be enabled. In order for a game to run at speed and for the programmer to have control of the Spectrum he will disable the interrupts.

GETTING TESTY

Dear Specman, I accessed the +3's self test mode on my +2A as per one of your previous columns and I actually got the result that my Spectrum had failed. My disk failed (which is good news as I don't have one on my +2A) my printer busy test failed (no probs, I don't own one), but what's really giving me sleepless nights is the fact that my rs232 test failed. What is it, why did it fail, where can I get it repaired and where can I get in touch with a good sleep therapist. Also, what the **** is an azimuth screw.
Stuart Hall, Kidderminster.

Well, Stuart this is a serious case of 'a little bit of knowledge can cause a lot of damage'. The rs232 interface is a way of making the Spectrum, or any other computer for that matter, communicate with other computers. I say communicate with each other, mind you, not run each other's programs. The rs232 interface was invented as an industry standard for communication between computers. During the test your Spectrum was requesting something to talk to but wasn't having any luck (poor Speccy!) so your test failed. This is not unusual, Spectrums are lonely, solitary machines that don't breed very often. All is safe and sound and you can sleep again at night. Second question: An azimuth screw is the small hole that you see on the top of your built in tape recorder, just above the rewind button. It can be altered using a small screwdriver to load misaligned tapes.

GOIN' WEST WITH MA' SPEC

Dear Specman, My family is going abroad to live and I have a massive

games collection as well as a Spectrum 128. What I want to know is will it be possible to use my Spectrum in America???

There are two problems here. Firstly the TV system runs on a different standard, and secondly the electricity is 110 volts in the states as opposed to 220 volts here in Blighty. The standard Spec will not survive. Although the Americans did have their own Spectrum, the Timex 1000 and 2000. The only way to do it is to buy a world standard TV (pricey) and a 220 volt to 110 volt converter (just ask about it in an electrical supply shop).

Z80 MATEY

Dear Specman, The Z80 inside the Spectrum runs at a set speed. If I replaced it with a faster one would I be able to get more speed out of my Speccy?
D. Johnson, Clwydd.

'Fraid it doesn't work like that, the CPU communicates with all of the chips inside the Spectrum at a predetermined speed. Speed up your CPU and it has a problem communicating with the outside world. If it was possible, believe me, accelerators would have appeared a long time ago for the Speccy. So be happy with what you've got Don Johnson, it's fast enough.

HEADLESS ANTICS

Dear Specman, What is a headerless program and how do I load it.
Paul Black, Staves.

Straight to the point here. When your Spectrum saves out a piece of code it puts a 17 byte header in front of it to load it in. This tells the Spectrum things like where it loads to and the auto run number etc. However by a simple 14 byte program you can save out the Spectrum's memory and load it back in directly by using the Spectrum's load a byte routine. Here's the assembler you require.

DI DISABLE INTERRUPTS

```
LD IX, START 16384 TO 65535
LD DE, LENGTH 1 TO 65279 BYTES
LD A, 255 SIGNAL TYPE DATA
CALL #04C2 CALL SAVE BYTES
EI ENABLE INTERRUPTS
RET RETURN TO BASIC
DI
LD IX, START SAME AS IN SAVER
LD DE, LENGTH SAME AS IN SAVER
LD A, 255 SIGNAL TYPE DATA
SCF SIGNAL TO ACCEPT
CALL #0556 CALL LOAD BYTES
EI ENABLE INTERRUPTS
RET RETURN TO BASIC
```





Last Christmas was a pretty spectacular time for Speccy beat 'em up fans. US Gold launched Final Fight, Do-mark launched Pit Fighter and Ocean launched the excellent WWF Wrestlemania. Now, in the wake of the Dream Team, Ocean are offering those of a more violent disposition the opportunity to partake in all three head breaking block busters.

Settle down with a good joystick and a competitive friend and prepare for some not so subtle action. Pit Fighter was launched amid much expectation - the coin op had interesting digitised sprites but lacked decent gameplay. Would the computer version suffer the same fate? Well, yes and no.

Pit Fighter involves taking over the body and mind of one of three characters. Ty the kick boxer, whose special moves are the spin kick, the flying kick and the roundhouse; Kato, a third dan karate black belt whose moves are the Combo punch, flip kick and backhand; Buzz the ex pro wrestler whose special moves are the body slam, the headbutt and the piledriver.

Pit Fighter is best played in two player mode. There is some time lapse between command and response but the sprites are big and good looking (if a little more transparent than usual) and the game doesn't suffer too much from the delay. The way the digitisation is emulated means that Pit Fighter is one of the most distinctive looking games ever on Speccy.

The route to fame and fortune in the shady and highly illegal world of pit fighting is torturous. You must defeat seven of the eight street warriors by punching, kicking, wrestling or throwing objects at them before you get to the final challenge, the Ultimate Warrior (not the WWF chap, don't worry).

Not an all time classic beat 'em up but not just a novelty item either. Pit Fighter is possibly better on Speccy than any

other format if only because expectations were not as high and more than usual ingenuity was needed to make it look respectable.

What can be said about WWF Wrestlemania that wasn't said last month? Well for all those who didn't catch it in Big Al's review of the Dream Team I'd better go through it in brief.

WWF is the top wrestling simulation so far available for the Spectrum. It combines big names from the World Wrestling Federation with relatively simple moves and lots of playability. You take on the mantle of either Hulk Hogan, The British Bulldog or The Ultimate Warrior (and all their associated registered trademarks, copyrights and general regalia) and attempt to beat the hell out of five other wrestlers from the WWF's bad guy camp.

The sprites are well drawn and instantly recognisable and all their moves are superbly animated. Each character has a special murder move and can jump off the ropes, kick, clothesline, shoulder charge and lots of other vicious things. The intro sequence to the game is well happening too and you'd do well to leave it on for a while and impress your friends.

Final Fight was another eagerly awaited coin op conversion, released at the same time as WWF last year. Like Pit Fighter the main concern seems to be accurate reproduction of the sprites and graphics and, true to form, the programmers succeeded admirably in this task.

The basic idea behind the game is that an ex wrestler and street fighting champion Hagar

GAME: Super Fighters
LABEL: Ocean
MEMORY: 128K

ISUI
SILVER

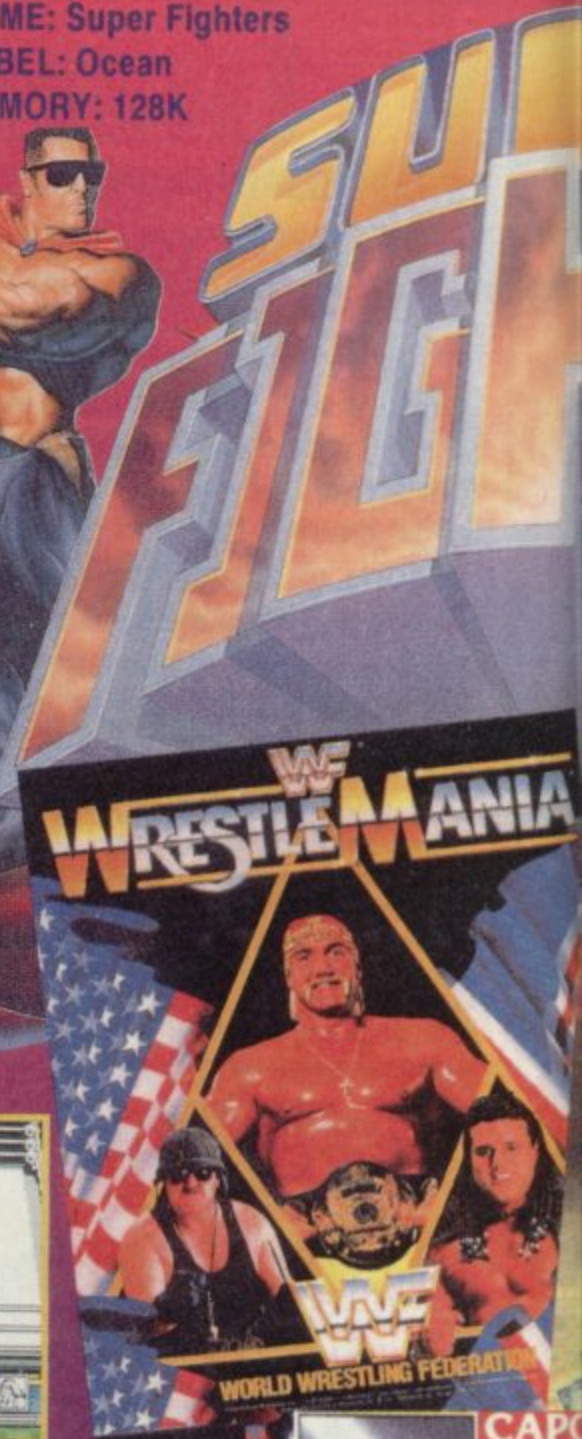

18



▲ Hulk gets it from Warrior.



▲ Well drawn sprites and animation.



▲ Digitised arcade Pit Fighter action.



▲ Hulk throttles Warrior.



▲ Who's that fat bar steward?



▲ Good looking but vicious.



▲ Who to beat up next???



TAPE £10.99
DISK £15.99

ISUI SILVER



FINAL FIGHT



(and, believe me, he is horrible) has been made mayor of Metro City, the most doggone crime ridden metropolis on the planet. Presumably the good citizens thought that fire needed to be met with fire, and only a mean, thick, brute who can't get a decent shirt to fit him could control the city's criminal underworld. (Or was that underwear?)

Anyway the criminals are obviously not impressed and have shown their complete disregard for the law by kidnapping Hagar's daughter. Now Hagar aided by Cody and Guy, two all American crime fightin' meat-heads, must rescue her. This is where you come in.

There are six levels of beat 'em up action, all shown beautifully on a map at the beginning of the game. You must fight your way through the subway, restaurant, lavatory, bay and hotel to reach the end and rescue the girlie. The bad guys, and there are many, will only be defeated by a sound thrashing, for which Hagar with his wrestling techniques, Guy with his ninjitsu prowess and Cody with his knife expertise are well suited.

Unfortunately control is a little confusing and restricting so fighting the bad guys can get frustrating at times, this is where the game falls down a little. The arcade was popular and good fun, though it didn't take long to dispatch your enemies. However the Spectrum version can get tiresome.

This is a good compilation if beating the hell out of things is your forte. The two player mode on Pit Fighter and WWf is fun and challenging and you're un-

likely to come across a better collection of excellent graphics.

Note that although Final Fight and Pit Fighter are both 48K and 128K compatible, WWf is 128K only so don't go buying Super Fighters if you only own a 48K machine.

Scores

OVERALL 87%
Steve Keen

Super Fighters is a good collection of fightin' games from three different companies. They're all good looking but unfortunately two, Final Fight and Pit Fighter, suffer from dodgy playability. Nevertheless if you don't already have WWf and you are a beat 'em up fan this compilation will be well worth your while getting.



Alan

Three graphically pretty games. WWf plays and looks good, Pit Fighter comes in second place with big, unusual sprites and average playability. Final Fight was potentially my favourite game but is let down by poor playability. However, the worst part about this compilation is that on tape the games take several centuries to load and must be constantly watched. This is annoying. If you have a +3 then opt for the disk version if you can get your hands on it.



▲ The Hulkster gets a pin.



▲ Final Fight kicks off.



▲ Oh oh! He's a comin'.



▲ Whoa! Gang fight!



▲ Hagar's gettin' mad!



▲ Jessica's boyfriend Cody.



▲ "Hi, Pizza, lots of pepperoni".

SEMI-MEGA

ALL ABOUT ANIMATOR1

On last month's Sinclair User we gave you a fully working version of the top art and animation program Animator1 (without Save & Load of course) and a beginners course on how to use it. In this issue we complete the tutorial and show you how to produce real animated graphics for commercial games and cartoons.

all instantly and remember them all without needing a mega Einstien memory! Here's how it's done... Press Caps Shift and keys 2,3,5,6,7,8 & 0 operate on the whole screen and its colour. Press X and they work on just the colour or press C and they work on the pixels and leave the colour where it is! Z allows fine movement while V lets you move the Magnify window around and switch it off and on.

SCROLLS/ ROTATES/ MIRRORS & MAGNIFY

There are an incredible 30 Scrolls, Rotates, Mirrors and Magnify options in Animator1 and by an ingenious use of special shift keys you can access them

20



mirrors



(move) scrolls



(on/off) rotates

CAPS

whole screen

Z

pixel screen

X

colour screen

C

course screen

V

magnify window

COLOUR OPTIONS

You can control the INK colour, PAPER colour, BRIGHTness and FLASHing all independently. This allows you to brighten or darken an area or make it flash without changing the actual colours or else change the colour of an area without changing its brightness or flashing.

Press CAPS SHIFT & 'D' (for the DESIGN MENU) and choose the BRIGHT option 8. Now enter 0 for BRIGHT OFF. Now everywhere you move the brush the screen area will darken, but the 'colour' will stay the same. You will find this, combined with the texture wash & erase option (as described in last months issue), is ideal for creating the shaded effects used in 3D objects. To set the option to BRIGHT ON choose 1, and to ignore the bright option you should choose 8 (the same as Spectrum BASIC!) This is exactly the same for the FLASH option and the INK & PAPER options except that you have 8 colours (0 to 7). If you choose colour 8 Animator1 will ignore the colour.

EXPERT TIP WHEN PAINTING IN COLOUR

As everyone knows, the Spectrum can display very good pictures indeed, but because of the way it holds the colours in big chunky squares, it makes it a lot harder to produce good pictures... Unless you know the tricks that professionals use - so here's just a few of them!

Plan your picture (or animation!) carefully so that any large single coloured areas 'roughly' match the Spectrum's character squares, then, when it comes to putting in the fine detail, you should find that you can 'knit' the awkward areas together by swapping the use of PAPER & INK colours.

Use Animator1's INVERSE option to quickly check where colour boundaries are (PRESS CAPS SHIFT & I). You'll find



Normal view of a lake.

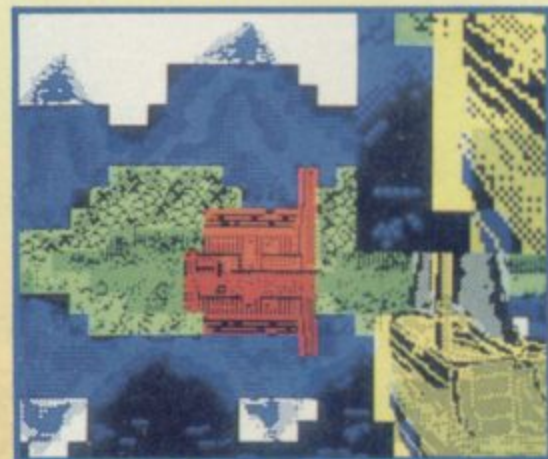

View using Animator1's inverse mode. This shows how the 'knitting' option is a handy way around the Spectrum's blocky colour.

the colour and texture options with the easy paint & erase control in Animator1 really come into their own in mastering this problem.

ANIMATION

Now you've proved you can draw like Rembrandt it's time to get animating! In the top left hand corner of Animator1 you'll see the Animator1's Sprite Window. This is like an animatable 'cut & paste'. Anything you draw in the sprite window (or SCROLL into it) can be STORED as a FRAME of animation. When you first load up Animator1, the window is set to 8 x 96 (that's 8 characters wide by 96 lines deep or 8 characters by 12 characters).

At this size you can have up to 17 frames of animation - that's a lot considering this is the 48k version. You can change the size of the Sprite Window to anything up to the size of the screen. The bigger the size, the lower the number of frames you can have. The maximum is 255 frames and the minimum is 2 frames. Press CAPS SHIFT & 'S' for the SPRITE MENU and here's what each option does:

1. STORE Stores whatever is currently in the sprite window to a frame you specify in memory.

PART 2 Using ANIMATOR1 to produce graphics for commercial games!

For more information on how to get the full version of this sprite and animation package, turn to page 30

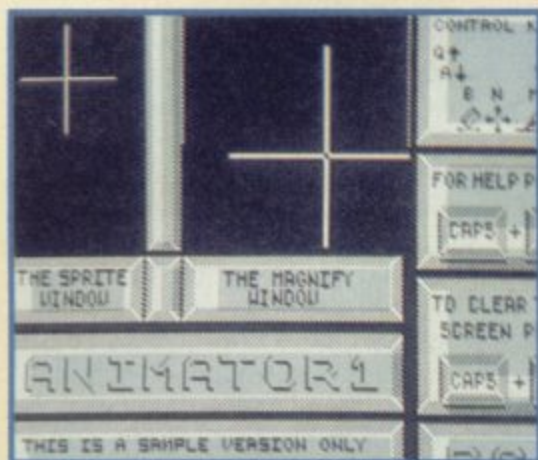

Circle mode's accurate cross hairs.

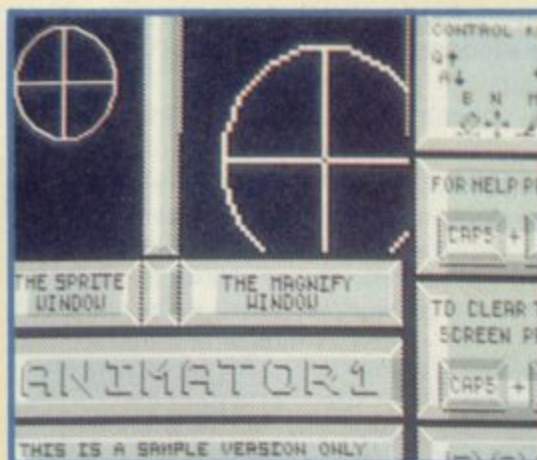

Animate those bubbles man!

2. FETCH Fetches the frame you specify 'from' memory (replacing anything that is currently in the Sprite Window).

3. ANIMATE Allows you to animate any consecutive frames and specify the speed of animation. (Choosing speed 0 allows you to single step frames by pressing any key while in animation mode (try the 'n' key here). Pressing RETURN returns you from animating.

4. CHANGE Allows you to change the size of the window from 1 x 8 (the size of a single character square) to a maximum of (the size of the screen). Remember, the second number is the depth in LINES - unless you are using this for machine code games you should always specify multiples of 8.

5. AUTO This has been included for speed - it AUTOMATICALLY stores the current contents of the sprite window to whatever frame you last stored or fetched.

Your first animation. First choose a large BRUSH and rub out whatever is in the SPRITE WINDOW. Now go into CIRCLE MODE (SEE LAST MONTHS ISSUE!) and draw a 1" circle in the SPRITE WINDOW and then EXIT CIRCLE MODE. Now select the SPRITE MENU and STORE this in FRAME '0'.

Now, using CIRCLE MODE'S very accurate positioning, ERASE the circle and draw a slightly smaller circle (taking care not to move the position of the cross hairs!) - and then STORE it as FRAME '1'. Now select the SPRITE menu and choose ANIMATE. Answer 0 for FROM? and 1 for TO? and 1 for PAUSE? And there you have your first animation... a wobbling bubble!

It's a really simple animation but yet you've seen this effect used in lots of games. And it's that simple. (Try making it 'pop' or explode using 4 or 5 frames!).

be pleased to know that MERLIN1 is the main SPRITE for that game and MERLIN2 is its colour so you can redesign it and load it back into the game - using Animator1 of course!

To load the Merlin sprite into Animator1 first set the SPRITE WINDOW to 4 x 96 and owners of the full Animator1 should then follow the normal LOAD SPRITE

prompts as normal, keeping to this size load MERLIN1 first as the BIT IMAGE and MERLIN2 as the ATTRI IMAGE (the colour).

Unfortunately, only readers who have sent off for a full copy of Animator1 will be able to save the sprites and load them into the MERLIN game, because the covermount demo version of Animator1 can't SAVE or LOAD. So there's all the more reason to take advantage of our £5 off voucher and treat yourself! If you only have the demo version of Animator1 you should do the following:

Set the SPRITE WINDOW to 4 x 96 BREAK out of Animator1 and do: LOAD "MERLIN1" CODE and play the tape followed by: LOAD "MERLIN2" CODE and play the tape. Now type RUN and press ENTER. Now you can freely redesign the Merlin sprite. If you want to reload it into the game, keep the (overall) size, shape, number of frames and the 'COLOURS' it already uses the same. The 'CROUCH' frames have special black ink & black paper areas above MERLIN - do not draw or put colour here. Other than those programming restraints, you can make your sprite as big or as little, as fat or as thin or even turn Merlin into a bouncing ball or an SAS combat soldier like last month's covermount! Remember that you only need to redesign 3 frames as the other three will be the reverse, so use the MIRROR and SCROLL options!

Once you've turned Merlin into a Punk Rocker or Ninja Frog, owners of the full Animator1 can now SAVE your new sprite to tape. Now load the MERLIN game and press BREAK and LOAD in your sprite as follows: LOAD "SPRITE1" CODE 54020 (this should be the BIT IMAGE (dots) of your sprite) LOAD "SPRITE2" CODE 56380 (this should be the ATTRI IMAGE (colour) of your sprite) Now you can run the program by rewinding the tape to the start of Merlin's title screen and typing: LOAD "" SCREENS: RUN 50, and there you have it - your own sprite in a commercial game!

MORE ADVANCED ANIMATION

OK, here we go. On this month's covermount there's two files called MERLIN1 and MERLIN2 and there's a giant cartoon style game called 'MERLIN'. Well, you'll



tell it to ALL



NOT EXACTLY CRYSTAL CLEAR

Dear Al! There is no way I can accept Codies reason for charging £9.99 for Crystal Kingdom Dizzy. If they consider that this as offering the equivalent of four games then their standards are dropping. The problems, such as they are, are simple to solve, and most of the resistance is offered by is offered by worms, birds, bats and rats. Level four is nothing short of pathetic, a few locations and, well, the less said about the collectible items the better. If ever a game seems to have been rushed out to meet a Christmas deadline this must be it. All I can say is that I expect at the very least to spend days, maybe even weeks on a Codies title, not seven hours like this baby took. As much as I'd like to think I

have improved in leaps and bounds since Spellbound Dizzy I don't think I've got that good.

PS. December's Great 8 was the best yet. Billy, Selton, Merseyside.

Well Mr. Billy, (not Fish I hope) this is an interesting letter. I'm not sure I totally agree with you though. I like Crystal Kingdom. OK, maybe there isn't as much excitement and as many new features as we would have liked, but it's still a playable and enjoyable game. As for the £9.99 price tag, yes, as far as Dizzy games go it is expensive but, I'd prefer to pay for it than not have it (oo-er). All of Codies' Dizzy series have been exceptional value and I still think this one deserves buying. Thanks for the solution though, we'll print it soon and in the meantime keep an eye on your post box for some goodies in return.

KEEPING UP WITH THE SMITHS

I have noticed recently that WH Smiths only seem to stock budget games for that Spectrum whereas all other formats are available at full price. Why is this. Surely there are enough full price games still available and people to buy them to warrant at least some shelf space. The only computer shop near me has turned into a console emporium and doesn't stock Speccy games any more so WH Smiths is my only salvation. Now though I may have to turn to mail order - even though I've been ripped off before and really don't trust mail order companies. Bernard Mace, Thirsk, N. Yorkshire.

Yes indeed, it is sad to see this happening but I'm afraid mail order of one sort or another may be our only salvation in the future. I be-

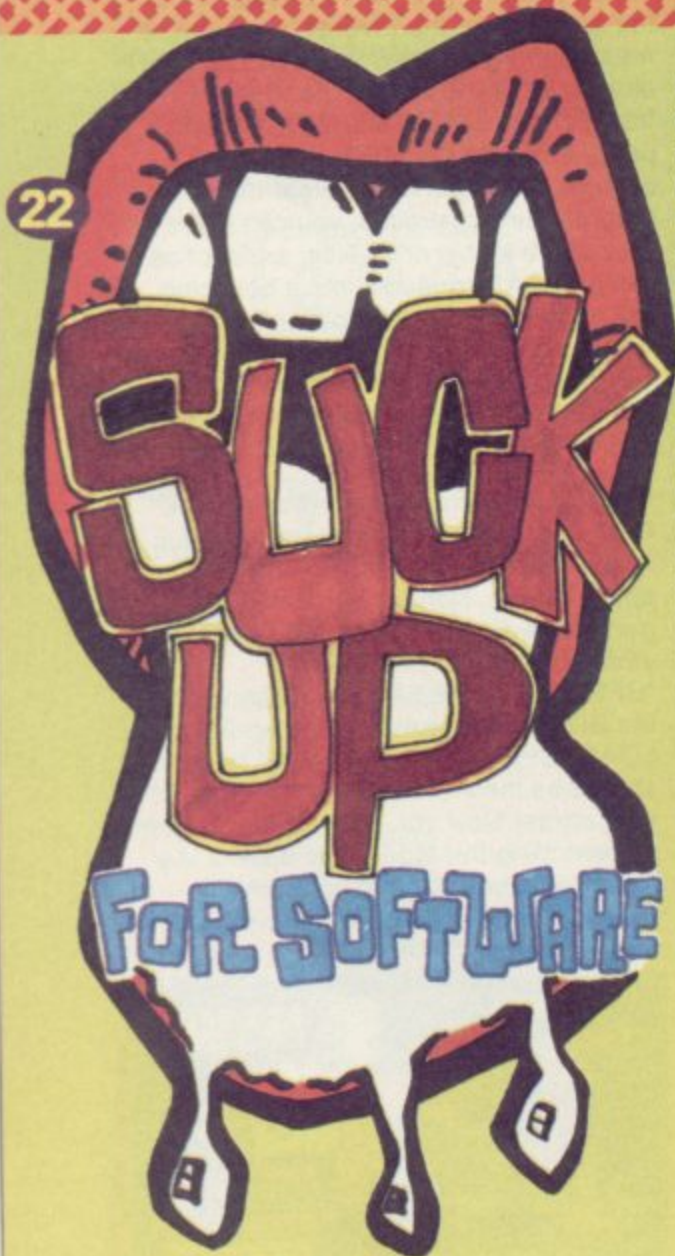

DEAD AND GONE

Dear Al, I go to school where nearly everybody has an expensive console and brag about the new games they can get. I seem to be the last of a dying race at my school with a Speccy. Although I

love the tradition about the Speccy, waiting ages for games to load, or crashing now again, I am unable to brag about my beloved computer and all the attributes it has. That is until, in your fabulous mag, an excellent review of Street Fighter 2. Wow! I can now amaze all my friends, with not only this but also with Lemmings!..... If only I had the games. I am sure that on seeing these, all my friends would be instantly impressed and go to the nearest shop to buy your wonderful mag and be transported into Speccyland too. So if you want to increase sales on your mag and also stage a great public relations stunt, I will oblige by showing my friends these two wonderful games, if you will send them, or even just one of them to me.

Your humble servant, Somewhere in a town with a rubbish Football team called Luton. Dan Carrol.

- *Well, I think you're telling a fib! We didn't review Streetfighter 2 a few months ago, we previewed it. I agree that the graphics would impress your friends but if they're console users all hope is lost for them anyway. We don't need that sort of PR.*

WHERE HAVE THEY GONE

Dear Al, I belong to a secret group known as D.G.D.S (Disappearing Games Detective Service). My codename is Pusi - Gehen - Wahrscheinlicht. You may have heard of me. but you probably haven't. I am on a mission. My boss tells me that because of my high success rate (I've found two games so far!) I have been given a tough but oh so important

challenge. So far I have found Tetris, an extremely rare game for the Spectrum which I found in a small town near Bridlington. Also I've found Mario Bros, a very rare and very naff game (only because it's hard). Anyway, the two games appointed to me are Prince of Persia and the compilation pack containing Cleudo, Monopoly and Scrabble. I have trekked to Devon, Edinburgh and places you've never heard of in this country searching for the games. Many a time I have found one game out of the compilton and returned with it, but the boss wants them together. After years of hard work my job is being threatened, I'm writing to you because I know you can get these games in your grasp.

I've heard a lot about you Al, We've given you a code name here at head office it is Sex - Auf - Bein. You have excellent potential and seem the perfect man to join our group. Finding these games will be the real test of your abilities. I will understand if you are happy in your present job, but we would appreciate it if you could help us in some way. I am an esteemed artist and would gladly send you some of my work in return for your cooperation. I will have the members of the group wear tattoos with your name in them. So how about it? is it a deal?

P.S. We have access to quite a few cheats we are willing to give for your kindness.

P.P.P.S. I've enclosed a piccy of Winona Ryder cause I know you think she is quite nice cause you mentioned it in one of the issues (No.125 - July 1992 to be exact). Come on you can't let me down after I've made all this effort. I'm not even asking you to print the letter but please respond!

lieve some WH Smiths are still carrying full price stuff but because small cassettes take up less shelf space than big boxes most are concentrating on budget titles. And not very many at that. Reliable m.o. companies like Software City are still around though so if all else fails you can turn to them.

BUSINESS SCHMIZNESS

I'm writing about the so-called business software on the Great 8 in December 1992. I will readily admit that Cash Book is actually very useful, and once you get fully to grips with how it works it's good, however Instant Recall and Page System Word Processor are rubbish. Recall seems to have little use and is very difficult to manipulate. Page System is so basic as to be of little use to me. You would have been better off putting Total Recall and some other arcade game on, then I would have had much more fun. Mr. J. Peters, Dorchester.

Flippin' heck, some people are never satisfied! I'll tell you what Mr. Peters, I'll write to you for approval on every single game or utility that goes onto the Fun 4 or Great 8 from now on. Will that satisfy you? Instant Recall is in fact an extremely useful Database and once you understand how to use it

properly you'll realise this. Yes, Page System is rather basic but then again not everybody is a know it all, done it all before, super human like you. Our tape software is intended to appeal to a wide variety of people, thus not everything included will everyone.

JUST THE JOB

I would like to congratulate you and the SU Crew on a job well done in the last two issues (Nov & Dec 1992). Not only were the mags themselves up to their usual terrific standard but the Great 8 was much better than ever before and quite frankly blew ** your rivals out of the water. Your tape has provided my grandson with plenty to keep him going for the next few months and you can be quite sure that I'll be purchasing your magazine for the foreseeable future, along with some of the games reviewed in it! Alfred M. Jarvis, Newark On Trent.

Why thank you Mr. Jarvis. I've gone all shy and bashful. It sounds as though you are enjoying the magazine too. I'll bet your grandson isn't seeing as much of his Spectrum as he used to!

PHILIP WHO?

Dear Al, I've noticed a very handsome

face appearing in your mag for the last two months (apart from your own of course) and it's name appears to be Philip Lindey if my eyes serve me well. Where did you get this hunk from? He not only seems to know everything there is to know about games and the spectrum but his style of writing is such that he is obviously up there with Shakespeare and Wordsworth on a scale of all time great writers. Please get him to send me his autograph as I am in a permanent swoon over this Greek god of a man.

Carol Keane, London NW2.

Wow, hero worship for the lad. Well I never. However the fact that this letter was posted from Neasden combined with the fact that Philip's name is spelt correctly and the incorrect use of a lower case 'S' for Spectrum leads me to smell a rat. Carol Keane of London NW2, are you not in fact Philip Lindey of Neasden, London NW2, masquerading as a hero worshipping girlie in the hope that you will whip up a frenzy among the nation's tender gender and get a few more letters? Hmm... Thought so.

P.P.P.P.S. Hope you like the piccy. It took me ages. Dogmatix is a little big, but anyway!

Bye! Pusi - Gehen - Wahrscheinlich, Oldham, Lancs.

- *I'm afraid that Prince of Persia is only available as a 16 bit game now. However, the compilation you mentioned is available from Software City, I was going to send it to you then thought, well I don't want to go taking all the credit for the find, and you'll get it on expenses anyway. But I must say I do appreciate the the piccy of Winona Ryder, so there's something in the post. Also, by the way, the second Codename is really obvious (you naughty thing) but our German experts couldn't work out your own code name, well done. Hope your exams go well.*

LEMMING OUTA HERE!

Dear Al, As I was walking to school along a street with snow in every garden I noticed a small bloke in a dark blue frock and green hair. I stopped and thought to myself, how often do you see a little man in a dark blue frock with green hair, not very often I thought. So I followed him. He jumped down through a trapdoor in the turf and I just slipped in as it was closing. I looked around me, there were thousands of little men in dark blue frocks with green hair. Sitting on a golden throne was a slightly bigger little man with a red frock and green hair. He summoned towards him, 'David' he said 'I have brought you here to save Lemmingland from the evil Lemming eater. He will be coming in two months. Go away and practice on the game Lemmings.' So, you see I need Lemmings to practice on, but I come from a poor family and cannot afford to but it for myself. So please could

you send me Lemmings or Lemmings will die out completely.

P.S. I worship SU

Yours Truthfully, David P. Wright.

- *Didn't anyone ever tell you that it's very dangerous to go following strangers around the place, especially ones with green hair. But I don't want you to go worrying too much about the extinction of the Lemmings, if you ask me they've got it coming, in fact I don't know why they haven't wiped themselves out long ago, silly creatures!*

DIZZYNAPI!

Dear Suck Up, on my way home from the shops last Saturday after buying a copy of the very wonderful Crystal Kingdom Dizzy, I was hi-jacked, yes, you guessed it... aliens! (Dramatic background music, du du du duuuuh) They came swooping out of the sky in what looked like a pressure cooker covered in tinfoil with Christmas tree lights on top. They hopped out of their flying machine looking a bit dazed and all gangly in the legs. One of them (whom the others called 'Wour Garry like') spoke to me, he said 'Hand ovah yeh family like or yahl nevah see yah preshis game agin.... like.. man!' Well Al, to cut a long story short twenty eight days after handing my family over to the aliens there was no sign of the game, I'm beginning to give up hope of ever seeing the game again. Since I have not only lost my Dizzy game but my a regular source of pocket money as well I have no-one else to turn to but you. P.S. I'm beginning to suspect that they were not even proper aliens.

Yours Sincerely, Sam O'Leary, Mallow, Co Cork.

- *I can tell from your letter (cos I'm a bit sensi-*

tive I am) that you are a man torn apart by grief. Do not fear Sam, all is not lost, we here at SU sympathise with your terrible plight, we too are big Dizzy fans so we know what you're going through. Another copy of Crystal Kingdom Dizzy is on its way to you.

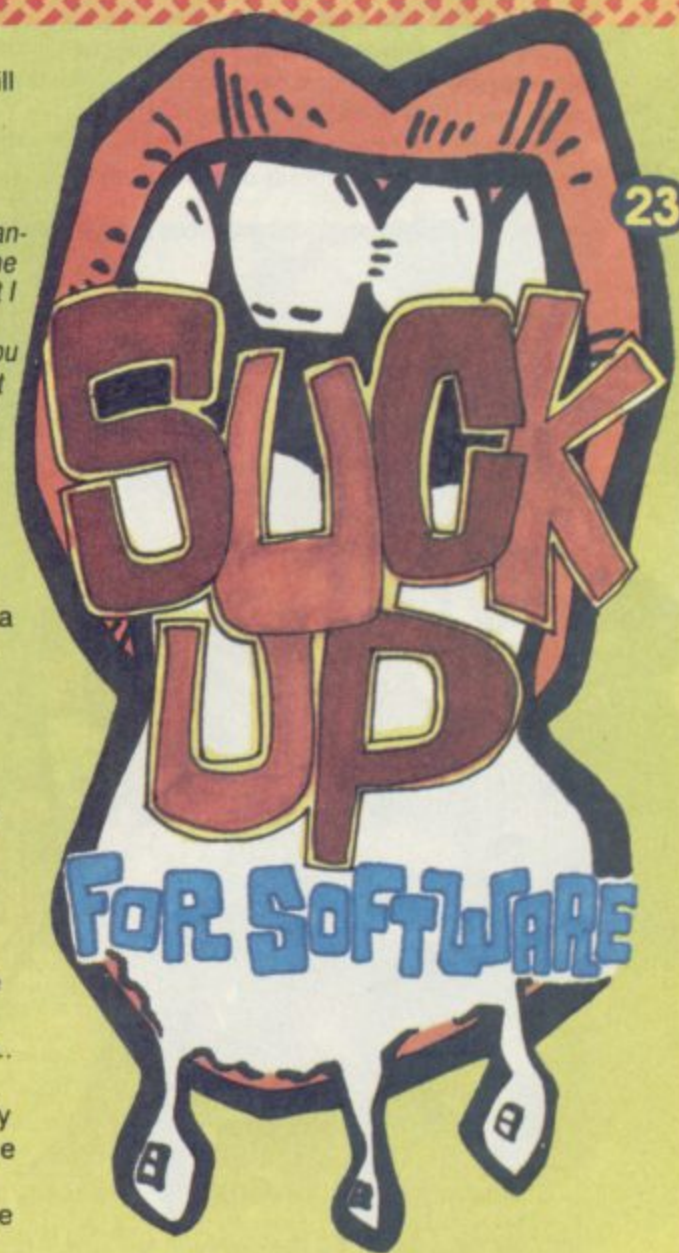

Greetings mortals! Not to put too fine a point on it (as *They Might Be Giants* might sing), I have recently been drenched. I set off on a shopping expedition to a nearby metropolis and, ignoring the clouds scowling overhead I decided to walk back home after I was finished. Hah! Bad move. When the weather is nice and sunny, colleagues wave at me from their chariots, exchanging cheery greetings and offering me lifts. When the weather is abysmal, how many wizards or sorceresses do you think I see? None whatso - Flippin' - ever! I am left to struggle on alone, only narrowly managing to stave off drowning.

Luckily for you I dried myself off before starting to write this, otherwise you might have turned the pages of the magazine upside down and drenched yourself in the ensuing flood!

Mmmm... interactive magazine fiction... now there's an idea for the future!

But back to reality and to the present. A name that will be familiar to regular readers is Gordon Inglis. For the benefit of any newcomers amongst you, Gordon, through the efforts of his company G.I. Games, was one of the main specialists in second-hand adventure software for the Spectrum and over the years he must have seen hundreds of adventures

coming and going. Not only second hand, though, as G.I. Games was responsible for its own collection of adventures as well as a vast public domain library of Spectrum games. You will notice that I said 'was' one of the main specialists...

I recently asked Gordon if he was actively

seeking new products, or just second hand ones. His reply was 'I am no longer active in any day to day way in the adventure market, and have no plans for any future games, as the outlay of buying the rights to over 30 games shows no sign of being recouped in the near future.'

This is sad news indeed from a man who says; 'I love adventure games.' A lack of spare time and the absence of any reasonable financial return both seem to have contributed to his decision to pull out of the market.

That, and a lack of response from the people for whom this service was set up in the first place. 'I was always looking for specific old adventures myself,' Gordon told me, 'and assumed that other people had a pile of finished games in cupboards but had no way of flogging them. So, I started selling second-hand



Witts End

**THE SHREWS
BURY KEY**
(From where we left off):

Drop record, s, e, out, e, n, se, s, se, in (police are after you, so remember directions on record!) E, s, e, e, e, out, get paper, e, in, up, swing, examine bed, get sheet, swing, pull rope, get rope, down, out, s, sw, s, use rope, drop rope, se, get pencil. Nw, n, nw, read file (need paper and pencil now), use pencil (copy file, which tells you how to build a raft), drop pencil, se, ne, open toolbox, examine toolbox, get cord, get saw, sw, s, se, se, e, ne, use card (now asked for a password, so remember graffiti). Use pilot (whoopee! fifty quid!), look, get note, sw, w, sw, buy wheel barrow, w, drop cord, drop paper, buy logs, get cord, e, ne, e, ne, n, nw, sw, s, se, make boat, use sheet... and for now I'll leave you sailing down a canal until next month.

THE SLAUGHTER CAVES
(More objects and their uses):

The shield protects you from burning oil, ignore the diamond, use the planks to bridge the river, hit the temple guardian with the mallet, the nails are not required. Use the fire (which won't be there if you've taken any treasures) to light the torch, drink the water in the pool to recover from attacks by beetles, the chest can be ignored. Open the tomb and burn the mummy with the torch, the wand is needed to open the temple doors, go back and get the crown after you have opened the temple doors, then sit on the throne and wear it. Choose the brass talisman and give it to the dragon, answer the dragons riddle correctly and the treasure is all yours, the end!

THE HOBBLE HUNTER
(Form where we left off):

Drop knife, e (the parrot squawks up for the fourth time, and can now be dropped), drop parrot, e, e (only with riding pony), e, ne, examine door, climb on saddle, unlock door, open door, dismount, drop key, n (ignore nail), examine leaves, throw turd at giant, s,

Where

games and operating a "Wants" list, which I stopped working with as lots of people who "wanted" a game never seemed to respond when you told them you had it for them! So it ended up being a first come first served second-hand list only.'

Don't worry there is some good news this month! Before we finished talking, and before Gordon departs from the adventure scene, I had to ask him 'out of all the games you have played, what is your favourite adventure?'

'I enjoyed games that have a good fun element in them, as too many adventure writers take themselves a bit too seriously, after all we are only talking about GAMES!'

'For this reason I waited with baited breath for each of the John Wilson's (alias Mr Zenobi!) "funny" games and was amazed and delighted with his wonderful one location "Behind Closed Doors" trilogy. It is a great shame and loss to the adventure market that John cannot put his great story-telling gifts to

use in more delightful games.'

Despite his decision to retreat from the market, Gordon, who admits; 'I have nothing but admiration for the likes of John Wilson of Zenobi,' tells me that all his games are still available and are being distributed by the aforementioned Zenobi Software at 26 Spotland Tops, Cutgate, Rochdale, Lancashire OL12 7NX. Good news!

They are also available from the Northern Underground, Top floor, 17 Fisher street, Carlisle. More good news!

The same address should also be contacted for details of the Spectrum Public Domain library, and for that one you should mark your SAE's for the attention of Les Floyd.

For people who are interested in second-hand games, one person to get in touch with is Richard Pascoe, who can be found at 127 Brampton Road, Newton Farm, Hereford HR2 7DJ. Don't

forget to include a SAE if you want to receive details of their current list of second-hand games.

It's always a shame when people like Gordon Inglis decide to call it a day, but with the likes of Zenobi, Northern Underground, and Richard Pascoe still active, there's hope yet! USE THEM, OR YOU MIGHT LOSE THEM!



Getting You Started

mount pony, say to Argo 'follow me' sw, w, w, w...to be continued.

THE LEGACY

(Objects and their uses):

Use the money to pay the taxi driver, insert the passcard into the slot to open the gate, take the brick from outside the gate and use it to break the window in the shack in order to let in some more light (you should then examine the shack), the fiver can be given to the butler, the ladder is surplus to requirements. Use the spade to dig in the back garden, pull the lever to open the nook under the staircase, attach the hook to the pole to pull the ring on the trapdoor leading to the attic. Use the battery in the torch, use the fan to blow away the dust in the nook, give the bone to the dog. The glass of water quenches your thirst after the heat in the hothouse... to be continued.

BERMUDA TRIANGLE

(Objects and their uses)

Use the £5 notes to buy a bottle of wine and kerosene for the lantern, place the floorboards across the chasm to form a bridge, the poncho keeps you warm on the icy ledge and puts out the fire in the shop. Use the spade to dig up the rope ladder in the garden, use the mortar and pestle to grind the vial of liquid into a potion, give the rope ladder to the bird to carry it up to the icy ledge then climb up to it. Insert the gold pin in the hole in the console, play the recorder to hypnotise the snake, insert the reed into the recorder, use the mattock to loosen the soil around the silver coin... To be continued.

THE GREAT PEEPINGAM TRAIN ROBBERY

(From where we left off):

Unlock cabinet, open cabinet, get diving suit, return to courtyard, find blunders, try to get west blunders west from courtyard, west, north, east, north east x3 blunders. Smash grille, north east, take mundle back to outside abbey, mundle, south west, south west, return to boat with mundle. Start engine, wait x4, take mundle to inn, get lantern and medicine, go through tunnel, wear suit and carry aqualung, swim lake, once swallowed by monster, get device, empty medicine, return to inn, get device to mundle, the end!

PRIDE OF THE FEDERATION

(From where we left off):

W, nw, n, push button, w, push button, w, n, drop truck, n, push button, e, push button e, (cameras follow your moves), s, e, ne,

examine screen, log on, password, ak5335. Alter temperature, captain, o, log off, sw, w, n, push button, w, push button, w, s, get truck, push button, e, push button e, put heat exchanger in red truck. Push button w, push button, w, s, s, push button, e, push button, e, e, e, ne, get heat exchanger off truck, drop truck. Connect heat exchanger, sw, s, w, nw, w, w... to be finished next time.

SINBAD AND THE GOLDEN SHIP

(From where we left off):

E, (old man asks you to carry him), s, u, hit gong with axe, hit chain with axe, e, n, n, hit skeleton with axe, enter cage, exam cage, get bar, throw bar, e, w, get orb, e, s, s, s, e, n, n, n, get gem. S, s, s, w, w, s, e, get berries, search room, get bottle, w, n, n, w, d, n, get man, n, n, w, e, n, n, n, n, fill bottle with water, s, s, s, s, s, get man, s, s, w, e, s, u, e, s, s, d, e... save data for next month

Sorceress

WHISTLE

(From the start of part one):

S, n, w, n, (by a castle), ring bell, up, n,

(guest bedroom), exam table, open drawer, get key, s, down, w, exam painting, unlock door, drop key, w, n, n (in a shed). Get spade, s, s, s, exam heap, get gloves, n, e, e, s, s, se, dig, drop spade, get sphere, exam sphere, n, w, n, (back to castle), ring bell, in, blow whistle, inventory, down, w, get pliers. E, up, s, s, se, w, w, w, wear gloves, get pot, exam pot, e, e, e, s, sw, (by a pool), go pool, drop pot, remove gloves, drop gloves, get toffee, n, n, n, e, e, s, e, (by a tree stump). Drop toffee and pliers, e, (in village), e, in, get knife, out, w, in, s, blow whistle, s, get mask, wear mask, n, out, blow whistle, drop whistle, s, s, in... to be continued.

THE CUP

(From the start):

North, get note and read it, north, north, east, exam chief, get chief, exam torches, get torch, exam furs, search furs, wear fur, exam pot, get pot, west, north, north, east, (repeat until elephants appear then follow elephants), north, ne, nw, north, east, south, exam keeper, tell story/fib/lie. Down, west, west, north, north, west, west, west, west, south, south, west, exam tree, hit tree (with club), drop club, get stone and exam it, kiss stone, north, north, ne, east, exam garden, exam soil, get trowel and exam it, west, sw... to be continued

Letters

26

Majid Khan, of London NW7 (not East 17 eh?), writes; Two of us have been playing the old game Blizzard Pass. As we try to complete our collection of adventures and we are having immense difficulty in crossing a fissure by a narrow ledge. We have a rope, and we have a ring, but whatever syntax we try to use we always end in failure. Is there something else that we ought to be using, or is it our wording that is letting us down?

* *It's the syntax, I'm afraid. This is one of those knotty problems (no pun intended) that crops up from time to time, and people will probably be struggling with it into the next century. Most people know what to do, but they don't know how to do it. So, for the benefit of Majid, and anybody else, the correct syntax to use is as follows; Tie Rope To Ring, Knot Rope, Throw Rope, Climb Rope. Enter those commands exactly, and you'll be over the fissure before you can say Clive Sinclair... Or Llanfairpwllgwyngyllgogerychwyrndrobwl - llantysillogogoch. Translated as St. Mary's church by the pool of the white hazel trees near the rapid whirlpool by the red cave of the church of St. Tysilio.*

Alf Mount, a Shropshire soul, writes; In Matt Lucas, I have managed to find the ignition key to a boat after looking around in Joe's place, and I've even managed to get some fuel for the boat after siphoning it out of a car. The only trouble is, every time I turn the key in the ignition and head out to sea, I run out of fuel before I'm allowed to get anywhere. I'm beginning to wonder if there's a fault in the program (but I'm sure it's just me being thick!), so could you please tell me what to do before I give up on this game (again!)

* *I almost hate to tell you this, Alf. Let me put it as kindly as I can; it's not a fault in the program. Actually, you're not being thick because you need to find a map, and it's hidden in a cunning place. You have to shoot a thug in the warehouse before he shoots you, and if you then LOOK you will then see that this particular thug has got a wooden leg. If you proceed to examine the wooden leg you will be told that it is hollow, and if you subsequently break the wooden leg you will find... fanfare of trumpets... the map!*

Tanya Robinson, who lives near Manchester, writes; I don't know if you remember me, but I wrote to you a few months ago about level 9's Ingrid's Back (Ah yes, I remember it well!) I'm new to adventure games you see, and I was told to buy some of their games. The point is, I'm stuck again! It's in Lancelot this time, but I've got a bit further than usual. I'm on the Isle of Thurnace with Galahad, and my problem concerns two dragons. I can't get any further than this, as I can't work out how to kill the dragons. Help!

* *You're nearly at the end of the game, Tanya, so your adventuring skills must be improving! As it happens, you don't kill the dragons, they must be made to kill each other. From the hillock, go S, S, S, S, to find the first dragon, then N, N, N, N back to the hillock with the dragon following you. Then in typical Level 9 style you must input GALAHAD wait with dragon, N, N, N, and when the second dragon follows you, go back to the first one and they will fight each other to the death. Then you carry on.*



SUPERMART SUPERMART

TO ADVERTISE IN SUPERMART CONTACT TINA ZANELLI ON 071 972 6700

Are You Missing Out on the VERY BEST User Group ????

Thousands of New Contacts Free Help & Advice. Second-hand Hardware, Software Bought/Sold/Exchanged. Exclusive massive Club Discounts. Latest product information and member reviews. Plus the best Fanzines and The Spectrum Software Collectors Guide. Plus Unique Spectrum PD Shareware Collection. Exclusive Newsletters, BBS and much more... Supporting all SPECTRUMS (48/+2/+3) and SAM Machines Find out what you're missing by sending an SAE on our FREE intro pack to:

C.C.C. (SU), P.O. Box 121, Gerrards Cross, Bucks, SL9 9LP; (0753) 884473

Trade and Dealer Enquiries Welcome. Plus FREE publicity for new software/fanzines etc. Contact us Now

KOBRASOFT SPECTRUM AND SAM COUPE UTILITIES

SAM DICE DISC UTILITY:- NEW! Features READ: BACKUP; RECOVER erased files/lost data; REPAIR directories: DISC CHECK; LOCK OUT bad sectors: SEARCH for a string; RENAME files: FORMAT all or one track - Price:- £12.95 Disc.
CD2 TAPE TO SAM DISC TRANSFER UTILITY:- NEW Transfer the vast majority of your spectrum tapes to sam drive. Gives superb Spectrum tape compatibility VERY EASY to use - Price:-£10.95 on Disk
SP7 TAPE TO +3 DISC UTILITY:- NEW! Transfer tapes to +3 disc. Now comes with a BEGINNERS Manual, and ADVANCED User Manual and a Encrypter Demo Tape. Also has superb DISC CATALOGUER and now will transfer FULL 18k programs INCLUDES SP7 COMPANION - Shows how to transfer many games. SUPPLIED ON DISC AT :- £14.95 - SP7 COMPANION VOL 2:- Transfer 100+ games. Needs SP7:-£4.95 **SC7 UTILITY NEW!** Latest tape to tape backup utility will now back up virtually ANY program - price-£9.95 on tape. **DMS +3 DISC MANAGEMENT SYSTEM:-** Version 1.1 now with printout, high capacity formats and extended directories, Search, MENU programs Easy to use - Price £14.95 **D.I.C.E. :- NEW** Version 3.0 +3 disc utility. Now with high capacity format, data printout and disassembler. Lock out faulty sectors; Recover erased files and much more. Easy to use "An excellent package" - CRASH Oct 88 - Price £14.95 on Disc **SPECTRUM MACHINE CODE COURSE:-** FULL Course from beginner to advanced level Applies to ALL Spectrums. Suitable for all. Free Disassembler AND Editor/Assembler - £20.00
SAM 2 80 MACHINE CODE COURSE :- FULL COURSE SUITABLE FOR LL COMPLETE WITH DISASSEMBLER AND EDITOR ASSEMBLER £20.00 **PLUS 3 DIARY AND FILING SYSTEM :-** NEW Version 1.1 with full printout Superb filing system /diary from the +3 with large database, fast search/retrieve, biorythms- £12.95 on Disc

ALSO AVAILABLE - SD5 TAPETO MD:SO5 TAPE TO OPUS : MII MD TOOLKIT : SWI TAPE TO WAFI DRIVE: SAM CT2 TAPE UTILITY: SMI M F SUITE. PLEASE RING FOR DETAILS

WE OFFER A FULL MONEY BACK GUARANTEE - BUY WITH CONFIDENCE UPDATE SERVICE - SEND HALF NEW PRICE + OLD DISC FOR NEW VERSION Send cheque/po to:- KOBRASOFT "DEPT SU" "PLEASANT VIEW", HULME LANE, HULME, LONGTON, STOKE-ON-TRENT, STAFFS. ST3 5BH (OVERSEAS AND EUROPE add £1 p+p per item, others £2) - Send SAE(9"X5") For detailed catalogue - mark envelope "enquiry"

For more information please phone:- 0781 305244
 Access, Visa Welcome - Please phone above number (24 hour 7 day service for FAST Mail Order)

SPECTRUM SOFTWARE HIRE

FREE MEMBERSHIP OVER 1,500 TITLES

Monthly Prize Draw / Newsletter

HIRE POSTAGE PAID
(1st Class)

For details and catalogue send S.A.E to:
**SSH (SU) 32, Dursley Road,
 Trowbridge, Wiltshire
 BA14 0NW**

SINCLAIR SUPPLIES

Spectrum +3 Computer	£99.99
Spectrum +2 Computer	£99.99
+2/+3 Compatible printer	£119.99
+2/+3 Parallel cable	£9.99
+2/+3 Serial cable	£9.99
Spectrum Datacorder	£19.99
+2/+3 Instruction manual	£14.99
+2/+3 Joystick Adaptor	£5.99
64K Watas x5	£9.99
Faulty +3 Circuit board	£14.99
+2/+3 Midi cable	£9.99
Membrane (48,+QL)	£10.99
48/128 +2 Power packs	£14.99
+2A/+3 Lightgun & Games	£14.99
Kempston interface	£12.99
4x CF2 Disks	£8.00
+3 Cassette Lead	£4.99
Quality Kempston Joystick	£9.99
Printer Ribbons	£4.99
+2/+3 Scart cable	£9.99
Spectrum 48/+128 Dustcover	£2.99

SPECTRUM REPAIRS



Only £15 if repairable. Send machine only, plus fault description. Phone for 128/+2/+3 prices. **FAST SERVICE.** Send CHQ/ PO to:
Omnidale Supplies, 23 Curzon Street, Derby DE1 2ES
 Tel: 0332 291219. Delivery normally within 7 days

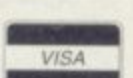

KEYBOARD ASSEMBLY-ZX SPECTRUM+2A/+3/+3A

£17.99
 Inc. VAT/Post



TRADE ENQUIRIES WELCOME

Spectrum +2 Power Supplies	£19.99	Spectrum +2A Cassette Mechanisms with tape head and motor	£29.99
Spectrum +2A/3 Power Supplies	£19.99	Spectrum Modulators (UM1233-E36)	£9.99
Spectrum Tape Head alignment kits	£9.99	ZX Spectrum 48K Membranes	£4.99
Spectrum Tape Head Demagnetizers	£9.99	ZX Spectrum 48K+ and 128K Membranes	£7.99
Spectrum SJS1 Joysticks	£9.99	ZX Spectrum QL Membranes	£8.99
Spectrum +2A Lightgun + 6 game cas	£14.99	Z80A CPU	£2.50
Spectrum +3A Lightgun + 6 game disk	£14.99		
Spectrum +2A Computers	£89.99		
Spectrum +2A Computer Handbooks	£6.99		

Prices include VAT, postage and packing



All orders sent by return: Cheque/Visa/Access/Postal Orders
Trade-In-Post, Victoria Road, Shifnal, Shropshire TF11 8AF
 Tel/Fax (0952) 462135



This is the final part of Larry Horsfield's PAW adventure writing tutorial. Remember, you'll need a full version of PAW to follow the instructions Larry has given in the last four months, but if you're serious about writing adventures then it's money very well spent. Meanwhile why not let Larry tell you how to saddle and mount your horse...

Last month we ended with just two problems left. How to saddle and bridle the horse. We will start with the saddle and there are two inputs the player can use to implement this action. Hold on though, surely the word saddle is a noun? Not to worry, there is an easy way around this, and that is to insert a "null word" as the verb. The two response table entries for the saddle, using flag 14, plus the entry for putting the bridle on the horse (flag 15), which is similar to the saddle, are thus:

```
PUT SADDLE PREP ON
NOUN2 HORSE
CARRIED 5
PRESENT 7 DESTROY 5
SET 14
OK
```

```
_ SADDL NOUN2 HORSE
CARRIED 5
PRESENT 7
DESTROY 5
SET 14
OK
```

```
PUT BRIDL PREP ON
NOUN2 HORSE
CARRIED 6
PRESENT 7
DESTROY 6
SET 15
OK
```

Now we come to the entry that will, provided all the gameplay has been completed, mark the final input in our mini-adventure, i.e. RIDE HORSE. First of all, insert the verb RIDE into the vocabulary as verb 41. You could also insert the verb mount as a synonym. Now go to the process tables and begin TWO new tables, 5 and 6. Before we insert any entries in Response or Process, switch to the message texts and insert the following messages:

Message 17: {The horse has no }
 Message 18: saddle.
 Message 19: bridle.
 Message 20: You don't have a sword.
 Message 21: You are not wearing the _.
 Message 22: You mount the horse and ride out of the castle to join your comrades on the dawn patrol.....

WELL DONE!
 You have finished the adventure!

You should position 'WELL DONE' in message 22 so it is in the centre of the screen, and you should put a blank line at the bottom using the ESCC7 routine. I have put brackets around message 17 as there is a space at the end and you'll notice that I've used the underline symbol in message 21. This will print as the object name in place of the "_" when combined with certain contacts in the respective entries. O.K., now go to the response table and insert the following entry:

```
RIDE HORSE AT 3
PROCESS 5
DONE
```

Now switch to the response tables and select Process 5. We will handle the conditions that determine whether the player can RIDE the HORSE by inserting entries in Process 5, checking to see if the player is wearing the helmet and chainmail, not carrying the sword and if the saddle and bridle are not on the horse. The checking entries in Process 5 are thus:

```
** NOTWORN 2      ** NOTWORN 3
WHATO             WHATO
LET 51 2         LET 51 3
MESSAGE 21       MESSAGE 21
DONE             DONE

** NOTCARR 4      ** ZERO 14
MESSAGE 20       MES 17
DONE            MESSAGE 18
                DONE

** ZERO 15
MES 17
MESSAGE 19
DONE
```

The WHATO action, "WHAT Object", is explained in the PAW manual, but in this case the LET 51 2, referring to object 2 the helmet (or 3 the coat of chainmail), indicates to PAW that that number is being referred to and the description of that object number is printed in the message in place of the "_" character. If you Print the system messages, you will see that quite a lot of them use this facility. The final entry to be inserted in Process 5 is the one which is acted upon when all the player is wearing is the helmet and chainmail, carrying the sword and the saddle and bridle are on the horse. This entry is thus:

```
** MESSAGE 22
SET 16
TURNS
END
```

We have not put any conditions in this entry because the previous entries have checked for the objects being either worn or carried and the saddle and bridle being on the horse. I have included the SET 16 line because of some of the entries we will be putting in later. If the player is wearing the helmet and

```
What should I do next?
^SADDLE HORSE
OK.

What now?
^PUT BRIDLE ON HORSE
OK.

What now?
^RIDE HORSE
You mount the horse and ride out
of the castle to join your
comrades on the Dawn Patrol.....

WELL DONE!!

You have finished the adventure

You have taken 25 turns.
Would you like another go?
^/
```

A Well done, you've completed the adventure and all is well. Now invent your own one or expand Dawn Patrol.

chainmail, carrying the sword and the saddle and the bridle are on the horse, when RIDE HORSE or MOUNT HORSE is typed in, message 22 is printed on the screen, the number of turns you have taken is shown and you are asked if you want to play again. The 'full solution' for the adventure, using the minimum number of inputs is, by the way, as follows:

U, GET TORCH, D, W, N, LOOK UNDER BENCH, WEAR HELMET, LIGHT TORCH, S, E, OPEN DOOR, S, GET SWORD, N, E, E, GET ALL, W, SEARCH STRAW, GET CHAINMAIL AND WEAR IT, SADDLE HORSE, PUT BRIDLE ON HORSE, RIDE HORSE..... Adventure complete

That, however, isn't the end of the programming. You may have realised that firstly we inserted another process table which we haven't used yet and that we haven't made any use at all of process table 2, which I explained was PAW's 'turn' at the adventure. There also isn't any rush to complete the adventure, although the storyline mentions that if you haven't joined your comrades, your commander will notice your absence. We will therefore use this part of the plot to provide a bit of excitement by having your commander come looking for you if you haven't completed the adventure within 30 moves. First of all, insert the two following messages:

MESSAGE 23: You hear a loud voice yell out nearby, "Private Smith! where are you hiding you 'orrible little man?"

MESSAGE 24: You hear footsteps behind you and a gruff voice shouts out, "Here he is! Throw him in the dungeon for failing to report for duty!" Two burly soldiers frogmarch you away and throw you in the castle dungeon! you took too many moves and have failed!

You should start each message by inserting a blank line at the top using the ESCC7 routine (i.e. Extend mode - 7 - Delete), and you should also put a blank line at the end of message 24. This



WRITING ADVENTURE GAMES

PART
FIVE



```
Under the gatehouse archway I  
can see, further to the west,  
the mounted patrol. I am supposed  
to be part of it. A low open  
doorway leads north, into the  
guard room, and the courtyard is  
east.
```

```
You hear footsteps behind you  
and a gruff voice shouts out  
"Here he is! Lock him up for  
failing to report for duty!" Two  
burly soldiers frogmarch you  
away and they throw you into  
the castle dungeon! You took too  
many moves and have failed!
```

```
You have taken 20 turns.  
Would you like another go?
```

A The fall message in Dawn Patrol. This adds an element of urgency to the game, players won't get away with being lazy.

is to separate the messages when on screen. After entering those messages, go to the process table and, in process2, insert this short entry: {* *} {PROCESS 6} Now select process 6 and insert the following entries:

```
** ZERO 16      ** ZERO 16  
ZERO 5          EQ 5 10  
LET 5 31        MESSAGE 23  
  
** ZERO 16  
EQ 5 1  
MESSAGE 24  
TURNS  
END
```

In addition to the ordinary User Flags (11 to 28 & 60 to 255) there are 9 "auto-decrement" flags (2 to 10) which are decremented if non-zero by PAW. Some of these as explained in the manual, operate under certain conditions, but flags 5 to 8 just decrement every input by the player or PAW.

In the last entry you have to make a "death" message appear when the flag you use equals 1, and hence add 1 to the number of moves when inserting the first entry so that the sequence will work properly. Once all the above has been inserted into your data-base, test the adventure and if you make some meaningless moves you will see the first message appear after 20 moves, then the final "death" message 10 moves later.

WHERE DO WE GO FROM HERE?

So far I have given you the instructions, the rest is up to you! You can expand 'DAWN PATROL' by inserting 'EXAMINE' messages and response table entries for all objects in the adventure. How about putting in more locations around the castle and maybe a puzzle or two of your own devising, it's all up to you.

If you are serious about adventure writing, I advise you to start by writing a small adventure, about twice the size of 'DAWN PATROL', and then work your way upwards to a full size adventure.

The average 48K adventure should be about 40 - 50 locations. There should be an evenly balanced number of puzzles ranging in difficulty from dead easy to quite hard.

If you are working in 128K, the game can of course be much bigger, but don't fall into the trap of putting in loads of 'walk through' locations. (If you are a 'humorous' adventure writer, watch out! Most adventure players are adults and do not appreciate 'modern' humour, nor do they like smuttiness or bad language, a lot of players are women).

OK, so you've written your adventure, now what? Well, if you're interested in a serious attempt at an adventure, you should have the game 'playtested'. This involves giving the game to someone who plays through the adventure, trying to solve the puzzles in various ways and checking for spelling and grammatical errors. You should give the game to a couple of playtesters first, then, once they have found bugs you can correct them. After this give the game to another two friends to playtest again, they are bound to find bugs the others missed.

MARKETING YOUR ADVENTURE:

At last you have a finished, play-tested and debugged, adventure. The big question now is how do you sell your game? The hard way to do it is on your own, and you should really sit down and consider what this option involves. It means buying blank cassettes, jiffy bags, stamps, paying for photocopies etc. not to mention hours spent loading and test playing copies of your adventure.

The alternative is to submit your finished adventure to one of the established adventure software houses, such as Zenobi software, FSF Adventure or The Guild. If you do this, don't just send a badly labeled cassette and a note saying 'this is my adventure, will you sell it?' as has happened to me a couple of times. Give whoever you send it to a full details of the plot, also provide a map and a full solution.

The software house will evaluate your offering and tell you whether or not they are interested in publishing it under their label. Don't feel dejected if your adventure isn't accepted, ask why it was turned down and what could be done to improve it. If your adventure is good enough the software house will accept it and you will probably be asked to sign a contract regarding the royalties the software company will pay you.

Whatever you do, you are not going to become an overnight millionaire. The adventure side of computer games is an ever decreasing section of the market and income from even the best selling adventures is quite small compared

to the vast amounts of money that can be earned from arcade games. Most adventure houses will pay you 30 - 40p per adventure sold, usually paid quarterly.

So, why do we do it? Well most of us are doing it because we love adventure games, and the money side of things is an added bonus. The only exception to this among the current Spectrum adventure software companies is Zenobi Software, better known as John Wilson, who has made a business out of adventure publishing which is his sole source of income. This is a success story which is unparalleled in the world of adventure writing, with over 100 titles currently available.

I hope my articles over the last few months have been of interest to you, and my tutorials have been easy to follow. I am willing to evaluate your games and help you out if you have any problems. Please give full details of your game and send a full copy of your data-base on tape, 3" +3 disk or 3.5" +D disk. Please note, however that I cannot help you with the plot of your adventure!

LARRY HORSFIELD
FSF ADVENTURES,
40 HARVEY GARDENS,
CHARLTON,
LONDON,
SE7 8AJ

Other useful addresses:

Zenobi Software,
26 Spotland Tops,
Cutgate,
Rochdale,
OL12 7NX

The Guild,
760 Tyburn Road,
Erdington,
Birmingham,
B24 9NX

Compass Software
111 Mill Road,
Cobholm,
Great Yarmouth,
Norfolk,
NR31 0BB

That brings me to the end of the last installment of my PAW mini-adventure programming tutorial. You should now insert a blank tape into your data-corder, blank, formatted disc into your disc-drive or whatever disk you've been using up until now and then select option M from the main menu to save your data-base. If you are using a disc version of PAW use the filename START for one save, then save the data-base again using a different name i.e. DAWN. you should always make at least two copies of any data-base as a precaution. Good luck with your new adventure writing hobby.

By Larry horsfield

ISUI OFFER

SINCLAIR USER EXCLUSIVE ANIMATOR OFFER £5.00 MONEY OFF VOUCHER!

If you were lucky enough to catch Animator1 (without load/save option) on the January Fun 4 then you'll want to get your hands on the full version. Now, at a super price, you can, allowing you to save all your great work for posterity. Just fill in the coupon below, and send it, with the £5 SU money off voucher to:

B.C.S. Grantham house, Macclesfield, Chesh, SH10 3NP

- ANIMATOR1 48K cassette: £16.95 (plus free Poster Machine program)
- ANIMATOR1 +3 disk: £24.95 (plus free Poster Machine program)
- ANIMATOR1 +D/ DISCIPLE: £19.95 (transfers to whatever disk is used)
- ANIMATOR1 'EXTRAS TAPE': £19.95 (All versions) Tape packed with goodies to use with Animator1 including: BRUSHES/ SPRITES/ SCENERY/ TEXTURES/ PICTURES and a complete 'load your own graphics' game.
- POSTER MACHINE: £9.95 as a separate prog (free with all versions of Animator 1). This is an incredibly addictive poster making program when used with Animator1's PRINT MODE, a forerunner to Quark Express!!



Please send me a copy of Animator1 on (tick where appropriate)

48K Cassette..... +3 Disk..... +D/ Disciple.....

Including Extras tape..... Poster Machine.....

I enclose a cheque/postal order/cash for £..... made payable to B.C.S or debit my Access/Visa (No.):

NAME _____

ADDRESS _____

POSTCODE _____



Make sure to use this genuine SU coupon and voucher to qualify for this great offer.

30

CHARTS

And now..... Direct from the very wonderful Software City, suppliers of games to the gods, it's The SU Charts. Funschool 2 has finally made it to the top, and what better way to keep the little ones off the streets! Meanwhile to keep all those train spotters and pub quiz fanatics going Trivial Pursuit has taken the charts by storm and Dizzy is well represented too. Good old football continues to dominate the charts as well. Way to go dudes!

1	Funschool 2	Hit Squad	£3.99
2	Trivial Pursuit	Hit Squad	£3.99
3	Football Director	D & H	£3.99
4	Thomas the Tank Engine	Alternative	£2.99
5	Crystal Kingdom Dizzy	Codemasters	£9.99
6	Football Manager 3	Prism	£9.99
7	Dizzy Collection	Codemasters	£9.99
8	Soccer 6	Zeppelin	£9.99
9	Super Fighter	Ocean	£10.99
10	Super All Stars	Codemasters	£9.99

GAME: Pipemania
LABEL: Touchdown
MEMORY: 48K/128K
TAPE: £3.99

Pipe Mania!!

ISUI

BEST BUDGET

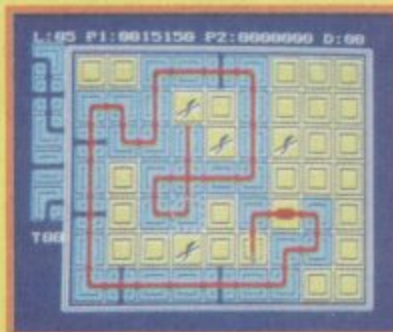
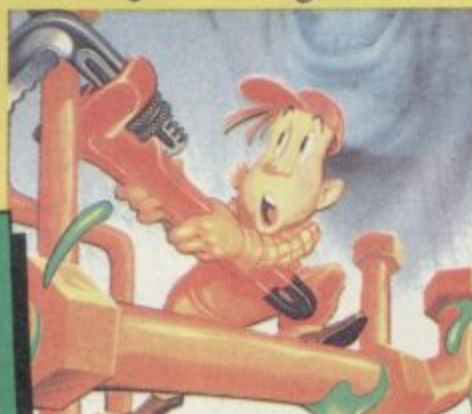

A Watch out for the hedge clippers!

Scores	
GRAPHICS	91
SOUND	81
PLAYABILITY	88
LASTABILITY	92
OVERALL 91%	

Big Al Dykes

Pipemania is one of those classic puzzle games. If you haven't got it I would strongly suggest going right out and buying it. Difficult at first but once you get used to it there's nothing more satisfying.



Steve

It's been a long time since I've played Pipemania and it took me a while to start thinking the right way again. Not for the easily beaten or feeble of heart, Pipemania is challenging and worthwhile having.

Dear Santa, you're useless. I asked you for a massive Skalextric set, a surf board and a few puzzle games for my Specky and all I got was three pairs of socks, a pink polo neck jumper and seventeen bottles of aftershave (which I don't use). Take my advice and find a new career...

If only Santa had realised that a good puzzle didn't mean wondering why all my

aunts and uncles gave me silly things for Christmas. If only he had included Pipemania in my stocking this criticism would never have occurred.

Pipemania is a completely simple concept but incredibly addictive. Take a grid, seven squares by ten, put a tap somewhere on it and provide a ton of copper piping all bent in different directions. Then give someone 20 seconds to start connecting pipes away from the tap before slime, the

tap's contents, starts to flow. The idea being to make the slime go as far as possible in your plumbers masterpiece.

You can blow up undesirable sections of pipe, get help from reservoirs which slow down the slime, pick up icons and generally get completely wrapped up in playing Pipemania. To start with it can be annoying but once you get the hang of this game you'll love it and probably never leave it.

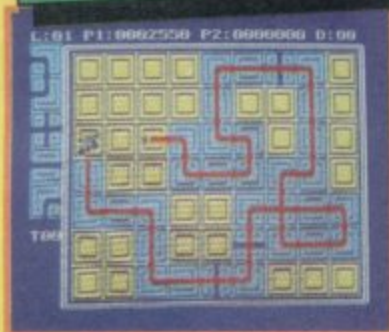

A And he's almost made it and... Boom!

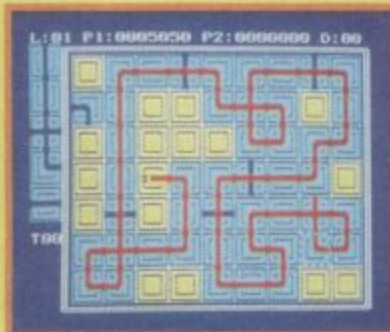

A Ever considered railroad planning?

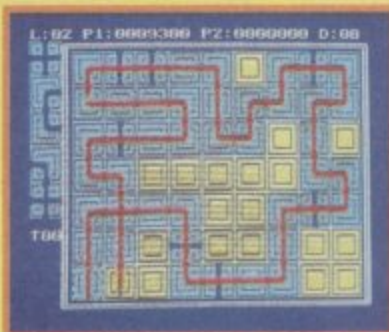

A Plumbers must have great fun!

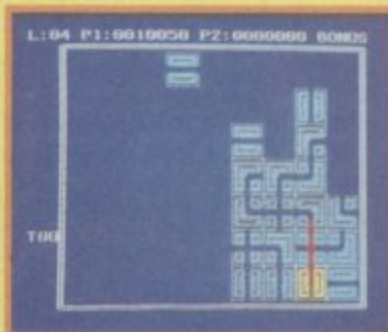

A The bonus game offer four levels.

Trivial Pursuit

ISUI

SILVER

The categories are Sport and Leisure, Science, History, Geography, Entertainment and Art and Literature. The idea is to move around the hexagonal board collecting slices of pie for correctly answering questions on each corner, which serve as the headquarters for each of the topics. Once you've won six slices, you must reach the centre of the board and answer one final question to win. Up to six people can play or more if you form teams.

This game is excellent, its only disadvantages compared with the original is that as a board game it was very social. Everyone sat around a table opposite each other having lots of fun. Now, on TV or monitor everyone must sit on top of each other, and concentrate on the screen rather than the other players. I also feel that unscrupulous people could cheat or argue more in this version. Steve Keen take note.

GAME: Trivial Pursuit
LABEL: Hit Squad
MEMORY: 48K/128K
TAPE: £3.99



Alan

If you're into quizzes then this is definitely the king. It's already riding high in the charts and was bound to be a Christmas success. If you haven't already got a copy get one, and get some pals in to play it with you sad person.

Scores

GRAPHICS	89
SOUND	70
PLAYABILITY	88
LASTABILITY	93

OVERALL 89%
Philip Lindey

This is the first time I've actually played Trivial Pursuit and I must say I'm pretty impressed. The questions are very intelligent and the layout of the game is marvelous. I also beat Big Al's first go.

All those family gatherings can get a bit trying. 'No you can't watch the telly, grandad is telling us about the Napoleonic wars', 'No you can't have third helpings, this has to last for sandwiches tomorrow you know!' Tsh! What you need is some mental stimulation.

Trivial Pursuit is, unsurprisingly enough, based on the best selling board game of the same name. You answer questions on one of six categories, or more frequently, fail to answer these questions because you haven't got a flip-pin' clue what the answer is.



FIGURE THAT

You can expect to see loads of action figures around this Christmas and we've collected just a few of the wondrous toys for you to cast your eyes over. Top (or bottom if you think they're a load of old ball cocks) of everyone's Christmas 'figures' list this year will be those awesome modern day warriors, The Gladiators. The figures themselves come in sets of one or two complete with event equipment such as jousting rods and rings so that you can stage your own contests. However if you fancy a more professional approach, scaled down versions of every Gladiatorial trial are also available. Settle your differences in the Atlaspheres, knock seven shades out of one another on the jousting podium, get to grips with the terrifying Wall and go for broke on the complete Assault course. All the games are fully functional with cranks, pulleys and rocket launchers etc. and it'll be the closest most of us (Big Al excluded) will ever get to the real thing!

Price: £4.99, £9.99, £7.49, £7.49, £9.99 and £14.99 respectively.



GOING FOR GOLD

We cover more games than the Olympics here at Checkout Central and this month is no different. Already hiding in some dark recess of your local toy shop is Creeps Castle. A brilliant game that's novel for two reasons. Firstly it's extremely fiendish and secondly you don't need to have a partner to play it! The idea is for a team of explorers to map out the innards of a spooky castle and find the rumored hidden treasure chest stuffed with gold. Easy enough, but the castle is haunted and dastardly traps and creepy cooks hinder your every move. Your character can be mysteriously thrown off a ledge, swallowed up by a trap or smashed to smithereens by the silver ball before getting to the end of a quest. The castle is loaded with eerie noises such

as creaking doors, and howling winds and trap doors and the like are bound to blow open at random all over the place. Brilliant, but simple fun for everyone and it won't dent your pocket either!

Price: £6.99

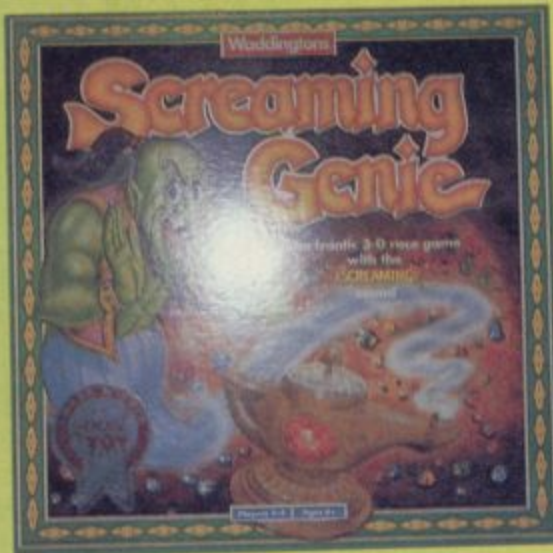

LET THE CAT OUT OF THE BAG

Waddington's have come up with some classic games over the years, but now they're moving away from the more traditional games and into the field of battery operated ones. Their latest, Screaming Genie, is a frantic 3D race game for one to four players. The first player to get to the lamp full of precious jewels and rub it will have all their dreams come true! However, if you should disturb the terrible genie as he sleeps you'll wake him up and he'll come out screaming. Then you'll have to grab as many stones as possible and race to the exit as he screams and screams and SCREAMS! Don't play this game late at night or it's liable to keep the whole street awake!

Price: £9.99



BATMAN

Next up are the incredible figures from that diabolical movie Batman Returns. You'll be pleased to hear that the toys fare a lot better than the flick under this reviewer's moniker, as we were all agreed at SU Towers that the film was diabolical! There are eleven characters to collect with tons of accessories including Bat Bikes, Bat Guns and Bat Mobiles. Each figure has a special move and packs some awesome equipment. You can lay your hands on the Penguin, Batman himself, The Joker and even Robin, who was never actually in the movies. And for those of you

CHI

Well Checkouters, I hope you've still got a little bit of that precious Christmas money left to splash out on some of Stevie Keen's super Checkout goodies. After all who knows when you'll get the chance again! The Christmas period may be over for another year, but there's

who are still salivating over the film's only saving grace, Cat Woman, you'll be thrilled to know that she's also on the shelves complete with whipping arm action (oo-er) and all her accessories. Steady boys!

Price: £4.99 to £9.99



MOULDED BLISS

Some toys will never disappear and here's one that's been a favourite with thousands of kids over the years. Shaker Maker is a very strange process that allows you to make your own models by pouring a special liquid into a mould and leaving it over night. The real fun is giving the moulding pots a real battering as you shake the solution inside to death to cover every part of the model. When the figures are dry you can then paint whatever designs you like on the surface! Everything's included and there are six different moulds and a whole set of paints and brushes. If you don't fancy the Trolls set there are others like The Flintstones and Scooby Doo, or if you want something completely different there's a similar Super Mario moulding and painting kit with Koopla, Luigi, Mario and Princess to make. Good fun for all ages, but it can be messy so parents beware!

Price: £12.99

CHECK OUT

no reason why you have to let go of its spirit just yet. Not when Mr 'seen it all and I've got the blisters to prove it' Checkout tells you what's lurking down at your local toy shop! So don't waste time moaning about what you didn't get. CHECK these OUT!



SAVE THE PLANET!

The last of our X-mas models features those incredibly right on dudes the Planet-ers. Yes, Captain Planet and the gang may not have taken off quite as well as some people would have liked, marketing men take note, but the cartoons and models are fab! Each figure has some really 'right on' stuff tucked into their utility belts including fully working compasses, guns that shoot water and reams of environmental tips in case they ever get caught short! There are seven in the set and some baddies too including MA-Ti, Kwame and the dreaded Duke Nuke 'Em! As usual several transport craft with special features can be bought, but the main attraction is the novel ecological approach each character carries. They're even biodegradable. Scientists Eh!

Price: £4.99 to £11.99

BUILDING BRICKS

It doesn't matter how old you are you never grow out of Lego. And the best thing about it is that when you have kids of your own you can play with theirs without needing an excuse! This Lego Technics set is the pinnacle of the engineering series. You can make over seven fully animated, robotic models out of the instructions included and countless others, imagination allowing! There are working models of bulldozers, cranes, dumper trucks, pick-up trucks and loads of others that are guaranteed to keep anyone busy for months. The set is a bit pricey, but why by

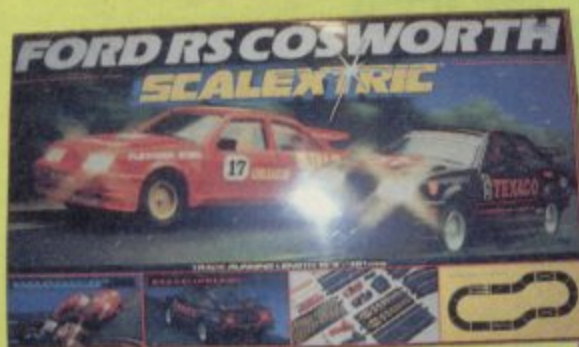

RACE AND CHASE

Ten years ago there couldn't have been many other toys that came before Skalextrics on teenagers Christmas Lists. I remember my first Skalextric set, it was the business, and I still can't spell it! Model car racing technology has come quite some way since then, and there are loads of different systems on the market like Tomy's AFX set and Matchbox's Race Arama, but the principle of all these speeders remains the same. Two cars race around a massive plastic track, powered by a small, completely safe low voltage power pack in a race to the finishing line. The brilliant thing about Skalextric is that it's



been around longer than any of the others and as such has built up a huge array of accessories including spare motors for the cars, trees, foliage of every sort, starting lights, sound effects modules and even smoke to recreate the burning rubber on the start line! It's like a modern day train set! This particular set features two Ford Cosworths complete with high embankments, chicanes, lap timer, 15'9" of track and brake lights. There are others available featuring anything from trucks to formula one racing cars. Just pick the one for you.

Price: £59.99



one toy when you can buy ten? All you need is in the massive box including motors, cogs, pulleys, wires and battery packs to make your creations come to life. There are smaller kits that you can expand upon to make up the big one in stages, but I'll be dreaming of this one for my birthday, won't you?!

Price: £67.00



COLOUR ME BAD!

Anyone who's ever pondered long and hard over some exquisitely drawn album cover or highly detailed technical drawing picture is likely to have been looking at an airbrush rendering. Airbrushing is a method of painting that incorporates a special 'wand' allowing the artist to filter paint over a highly pressurized stream of air blowing it onto the canvas. Some incredible effects can be achieved by the experts to reach almost photographic quality works of art. Until now an airbrush was likely to have set you back

around 150 and many people would have given up after the first few goes (it's not as easy as it looks!) However a company has brought out a cheap alternative. It's still great quality and full instructions are included so budding Picassos can get to grips with the basics before forking out on the big boys toy!

Price: £9.99



MOUSING AROUND

You may remember the original Etch A Sketch and if you don't we're going to remind you! Basically it was a slim red box that allowed you to draw all kinds of patterns on its screen by scratching on the surface of a mysterious silver film that covered its face. Drawing was achieved by turning two knobs on the left and right of the machine and once your masterpiece had been finished you simply turned the thing upside down and gave it a good shake and you could start all over again. Well this one's exactly the same as that except that it's got Mickey Mouse welded to its body. And rather cute it looks too. Mickey's always been a kids favourite and what better way to get the youngsters into drawing than this. Limited yes, but fun all the same!

Price: £9.99

**N
E
X
T**

34

**M
O
N
T
H**



Don't worry Jim, SU's on it's way!

The Spectrum in America: A Timex/Sinclair Special!

**NEW YEAR, NEW GAMES - What's happening
in Speccyland? UK Software Investigation!**

+ Best Game Roundup, Reviews, Previews & News

OUT 18 FEBRUARY

FREE! WHEN YOU BUY AN ST FROM SILICA



When you buy your new Atari 520, 1040 or Mega ST-E computer from Silica Systems, we will give you an additional £324.75 worth of software FREE OF CHARGE, including some great entertainment and productivity programs. These free gifts will introduce you to the world of ST computing and help you to get off to a flying start with your new ST. Plus, with every ST and TT, we will give you 16 nights holiday hotel accommodation for you and your family to enjoy a break at home or abroad.

TENSTAR PACK:

ASTERIX	£24.99
CHESS PLAYER 2150	£24.95
DRIVIN' FORCE	£19.95
LIVE AND LET DIE	£19.99
ONSLAUGHT	£24.99
PIPE MANIA	£19.99
RICK DANGEROUS	£24.99
ROCK 'N' ROLL	£19.99
SKWEEK	£19.99
TRIVIAL PURSUIT	£19.95

16 NIGHTS HOLIDAY HOTEL ACCOMMODATION
Every Atari ST from Silica comes supplied with a free 72 page colour brochure with accommodation vouchers. These entitle 2 people to stay up to a total of 16 nights in any of 250 hotels with accommodation FREE. All you have to pay for are your meals (prices are listed in the brochure).

PRODUCTIVITY PACK:

1st WORD*	£59.99
Word processing package from GST	
SPELL IT	£19.99
Spelling checker to complement 1st Word	
ST BASIC	£24.99
Basic programming language with tutorial	
TOTAL VALUE:	£324.75

WORTH NEARLY £325!
*Not supplied with STs where Atari pack already includes 1st Word

NEW ATARI ST PRICES

PLUS! FREE GIFTS FROM SILICA!
SEE PANEL TO LEFT



520ST-E DISCOVERY XTRA

HARDWARE:
1Mb RAM 520ST-E COMPUTER £249.99
8MHz 16-Bit 68000 CPU, 512K RAM, Mouse, TV Modulator, Internal PSU, 1Mb Disk Drive

SOFTWARE - ARCADE GAMES:
Final Fight - A superb street fighting game £25.99
9 Lives - Cartoon quality platform romp £24.99
Robot Monsters - Arcade Shoot 'em Up £19.99
Sim City - Take control of your own city £25.95

SOFTWARE - PRODUCTIVITY:
Neochrome - Art package £29.99
1st Word - Word processor £59.99
First BASIC - Programming language £49.99
ST Tour - Tutorial Disk FREE
ANI ST - Animation Package £29.95

PLUS! FREE FROM SILICA:
Silica Productivity Pack* £44.98
TenStar Games Pack £219.78
Total Value: £785.59
Less Pack Saving: £536.59
SILICA PRICE: £249.00

*Does not include 1st Word

£249
Inc VAT - Ref: STC 6300

UPGRADED MODEL WITH **1Mb RAM** **£279**
INC VAT - STC 6311

ATARI TT



- NEW LOW PRICE**
- 32MHz 32-Bit 68030 Processor
 - 3 1/2" 1.44Mb Double Sided Disk Drive
 - 2/4/8Mb RAM Versions
 - Stereo 8-Bit PCM Sound Output
 - 4096 Colour Palette
 - Built-in 68882 Maths Co-Processor
 - Up to 1280 x 960 Resolution
 - VME + SCSI Expansion Ports
 - Expandable to 36Mb RAM
 - Hard Drive Expansion Options
 - FREE 16 Nights Holiday Accommodation

2Mb RAM	4Mb RAM	8Mb RAM
£999	£1299	£1599
<small>INC VAT - STC 6805</small>	<small>INC VAT - STC 6806</small>	<small>INC VAT - STC 6807</small>

MEGA STE



- NEW LOW PRICE**
- 16MHz 16-Bit 68000 processor
 - 3 1/2" 1.44Mb Double Sided Disk Drive
 - 2Mb RAM
 - Hard Drive Options Available
 - 4096 Colour Palette
 - Stereo 8-Bit PCM Sound Output
 - FREE Silica Productivity Pack
 - FREE TenStar Games Pack
 - FREE 16 Nights Holiday Accommodation

SPECIAL PROMO PRICE!
2Mb MEGA ST-E (No hard drive)
RRP ~~£799.83~~ **£499**
Inc VAT - Ref: STC 8433



The new Atari Falcon 030 is here! It is a powerful, versatile, multipurpose home computer, offering unmatched performance for its price. Included in its advanced specification are multiple co-processors for sound and graphics, true colour displays from a pallet of over a quarter of a million colours and 16-bit stereo sound input for speech recognition and sound sampling. These all combine to provide a new computer capable of running unrivalled sound, graphics and multimedia applications. The Falcon is an ideal upgrade for Atari ST owners who are looking for a more powerful model, as it is compatible with the majority of ST application software.

ATARI ST MORE THAN JUST GREAT GAMES!



1040ST-E MUSIC MASTER

The Music Master Pack features one of the most popular computers used by musicians combined with the renowned MIDI package PRO 24 III to provide a perfect environment for novice and professional alike. The acclaimed MIDI Recording and Editing System from Steinberg, PRO 24 III is used by many top musicians including Dire Straits and PWL. Using any MIDI keyboard, PRO 24 offers the ability to write and compose music to a very high standard. You can record up to 24 tracks simultaneously, and then apply real time editing to remove mistakes.

HARDWARE:
1040ST-E COMPUTER £299.99
8MHz 16-Bit 68000 CPU, 1Mb RAM, Mouse, TV Modulator, Internal PSU, 1Mb Disk Drive

SOFTWARE:
PRO 24 III £150.00

PLUS! FREE FROM SILICA:
Silica Productivity Pack £104.97
TenStar Games Pack £219.78

Total Value: £774.74
Less Pack Saving: £475.74
SILICA PRICE: £299.00

NEW! LOW PRICE
£299
Inc VAT - Ref: STC 1261

The Falcon Has Landed!

- 16MHz 32-bit 68030 Processor
- 32MHz Motorola DSP and BLITTER co-processors
- DSP capabilities for voice recognition, speech synthesis and numerous audio special effects
- True colour display: 768 x 480
- 65,000+ colours on screen at once
- Record 8 channel, 16-Bit stereo sound and play back 4 channel, 16-bit stereo simultaneously
- SCSI II, DMA, MIDI IN & MIDI OUT, Stereo audio & microphone ports
- 1.44Mb Floppy Disk
- 1, 4 or 14Mb RAM Configurations
- Optional 65Mb Hard Disk
- Built-in ADC & DAC converters

ATARI FALCON 030

16MHz 32-Bit 68030 CPU, 1Mb RAM, 3 1/2", 1.44Mb FDD

HARDWARE:
CALAPT - Personal Information Manager - Enhanced version calendar allowing import/export & printing
PROCALC - Calculator
SYSTEM-AUDIO-MANAGER - An Auto Folder! Disk Accessory combination that allows the user to record sounds from a microphone and assign various system functions
TALKING CLOCK - Announces time at preset intervals
AUDIO FUN MACHINE - A revolutionary audio program using DSP
LANDMINES & BREAKOUT - Two fully featured games

£499 INC VAT
1Mb RAM, 65Mb HD - Ref: STC 7000
AVAILABLE FEBRUARY '93
£899 INC VAT
4Mb RAM, 65Mb Hard Disk - Ref: STC 7046

NEW! 1040ST-E FAMILY CURRICULUM II

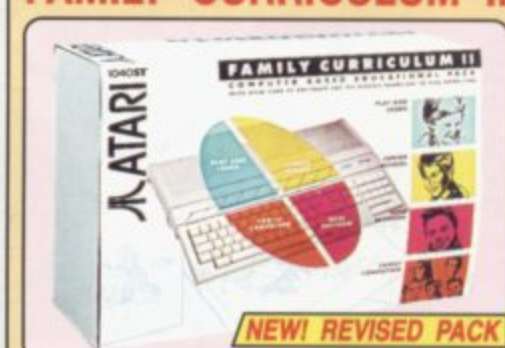

HARDWARE:
1040ST-E COMPUTER £299.99
8MHz 16-Bit 68000 CPU, 1Mb RAM, Mouse, TV Modulator, Internal PSU, 1Mb Disk Drive

SOFTWARE MODULES:
PLAY AND LEARN - A Game with Words and Sentences £76.59
JUNIOR SCHOOL - Answer Book/General Knowledge Quiz, Spelling and Primary Maths £58.54
GCSE - Micro Maths, French, and Geography Quiz £55.54
HYPER PAINT - Full Colour Paint Package £39.99
MUSIC MAKER II - Music Creation Software £49.99
FIRST BASIC - Powerful Programming Language £49.99
1st WORD - Very easy-to-use Word Processor £59.99
ANI ST - Animation Package £29.95

GAMES
9 LIVES - The ultimate in playability! - help Bob Cat save Claudette
PRINCE - Do battle in this tenth century game of warfare £24.99

PLUS! FREE FROM SILICA:
Silica Productivity Pack* £44.98
TenStar Games Pack £219.78
Total Value: £1035.27
Less Pack Saving: £736.27
SILICA PRICE: £299.00

PLUS! 16 NIGHTS HOLIDAY HOTEL ACCOMMODATION

ALL PRICES INCLUDE VAT - FREE OVERNIGHT COURIER DELIVERY IN THE UK MAINLAND

SILICA SYSTEMS OFFER YOU

- **FREE OVERNIGHT DELIVERY:** On all hardware orders shipped in the UK mainland.
- **TECHNICAL SUPPORT HELPLINE:** Team of technical experts at your service.
- **PRICE MATCH:** We normally match competitors on a "Same product - Same price" basis.
- **ESTABLISHED 14 YEARS:** Proven track record in professional computer sales.
- **£12 MILLION TURNOVER (with 60 staff):** Solid, reliable and profitable.
- **BUSINESS + EDUCATION + GOVERNMENT:** Volume discounts available 081-308 0888.
- **SHOWROOMS:** Demonstration and training facilities at our London & Sidcup branches.
- **THE FULL STOCK RANGE:** All of your requirements from one supplier.
- **FREE CATALOGUES:** Will be mailed to you with offers + software and peripheral details.
- **PAYMENT:** Major credit cards, cash, cheque or monthly terms.

Before you decide when to buy your new computer, we suggest you think very carefully about WHERE you buy it. Consider what it will be like a few months after you have made your purchase, when you may require additional peripherals and software, or help and advice with your new purchase. And, will the company you buy from contact you with details of new products? At Silica Systems, we ensure that you will have nothing to worry about. We have been established for almost 14 years and, with our unrivalled experience and expertise, we can now claim to meet our customers' requirements with an understanding which is second to none. But don't just take our word for it. Complete and return the coupon now for our latest FREE literature and begin to experience the "Silica Systems Service".

MAIL ORDER HOTLINE
081-309 1111



MAIL ORDER: Order Lines Open: Mon-Sat 9.00am-6.00pm No Late Night Opening	1-4 The Mews, Hatherley Rd, Sidcup, Kent, DA14 4DX Tel: 081-309 1111 Fax No: 081-308 0808
LONDON SHOP: Opening Hours: Mon-Sat 9.30am-6.00pm No Late Night Opening	52 Tottenham Court Road, London, W1P 0BA Tel: 071-580 4000 Fax No: 071-323 4737
LONDON SHOP: Opening Hours: Mon-Fri 9.30am-7.00pm (Sat close 6.30pm) Late Night: Thursday - 8pm	Selfridges (1st Floor), Oxford Street, London, W1A 1AB Tel: 071-629 1234 Extension: 3914
SIDCUP SHOP: Opening Hours: Mon-Sat 9.00am-5.30pm Late Night: Thursday - 7pm	1-4 The Mews, Hatherley Rd, Sidcup, Kent, DA14 4DX Tel: 081-302 8811 Fax No: 081-309 0017
ESSEX SHOP: Opening Hours: Mon-Fri 9.30am-5.30pm (Sat 9.00am-6.00pm) No Late Night Opening	Keddies (2nd Floor), High Street, Southend-on-Sea, Essex, SS1 1LA Tel: 0702 462426 Fax No: 0702 462363

To: Silica Systems, SUCRS-0293-79, 1-4 The Mews, Hatherley Rd, Sidcup, Kent, DA14 4DX

PLEASE SEND A BROCHURE ON THE ST RANGE

Mr/Mrs/Miss/Ms: Initials: Surname:

Company Name (if applicable):

Address:

Postcode:

Tel (Home): Tel (Work):

Which computer(s), if any, do you own?

"The biggest hero of them all" Amiga Power
is back in

CRYSTAL KINGDOM

DIZZY™

Includes
Codemasters
unique
GAME GENIE™
enhancer codes
for great
entertainment!

**Free
Poster**



**Free
Dizzy
Stickers**

High adventure, Rich rewards, Big trouble!

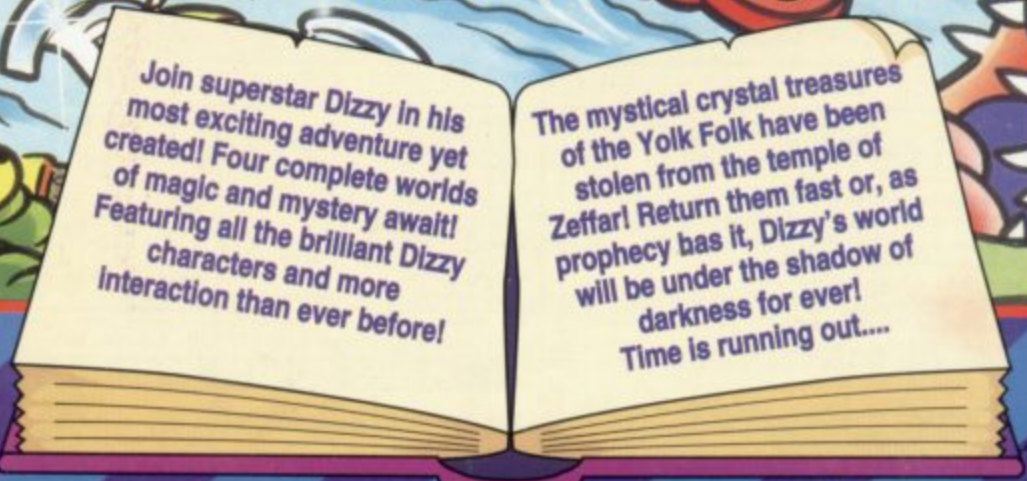

Join superstar Dizzy in his most exciting adventure yet created! Four complete worlds of magic and mystery await! Featuring all the brilliant Dizzy characters and more interaction than ever before!

The mystical crystal treasures of the Yolk Folk have been stolen from the temple of Zeffar! Return them fast or, as prophecy has it, Dizzy's world will be under the shadow of darkness for ever! Time is running out....

£19.99

£9.99

• AMIGA •
• ATARI ST •

• COMMODORE 64 •
• SPECTRUM •
• AMSTRAD CPC •



CODEMASTERS